

Service Manual

Pioneer

KEH-1940/X1M/EW

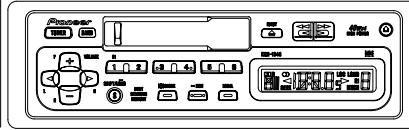

ORDER NO.
CRT2425

HIGH POWER CASSETTE PLAYER WITH FM/MW/LW TUNER

KEH-1940

KEH-1960

X1M/EW

X1M/EW

● This service manual should be used together with the following manual(s):

Model No.	Order No.	Mech. Module	Remarks
CX-644	CRT1800	2M	Cassette Mech. Module:Circuit Description, Mech.Description, Disassembly

CONTENTS

1. SAFETY INFORMATION.....2	7. GENERAL INFORMATION.....34
2. EXPLODED VIEWS AND PARTS LIST2	7.1 DISASSEMBLY34
3. BLOCK DIAGRAM AND SCHEMATIC DIAGRAM ..10	7.2 PARTS35
4. PCB CONNECTION DIAGRAM.....20	7.2.1 IC.....35
5. ELECTRICAL PARTS LIST.....28	7.2.2 DISPLAY38
6. ADJUSTMENT32	8. OPERATIONS AND SPECIFICATIONS39

PIONEER CORPORATION 4-1, Meguro 1-Chome, Meguro-ku, Tokyo 153-8654, Japan
PIONEER ELECTRONICS SERVICE INC. P.O.Box 1760, Long Beach, CA 90801-1760 U.S.A.
PIONEER ELECTRONIC [EUROPE] N.V. Haven 1087 Keetberglaan 1, 9120 Melsele, Belgium
PIONEER ELECTRONICS ASIACENTRE PTE.LTD. 253 Alexandra Road, #04-01, Singapore 159936

1. SAFETY INFORMATION

This service manual is intended for qualified service technicians; it is not meant for the casual do-it-yourselfer. Qualified technicians have the necessary test equipment and tools, and have been trained to properly and safely repair complex products such as those covered by this manual.

Improperly performed repairs can adversely affect the safety and reliability of the product and may void the warranty. If you are not qualified to perform the repair of this product properly and safely; you should not risk trying to do so and refer the repair to a qualified service technician.

2. EXPLODED VIEWS AND PARTS LIST

2.1 PACKING

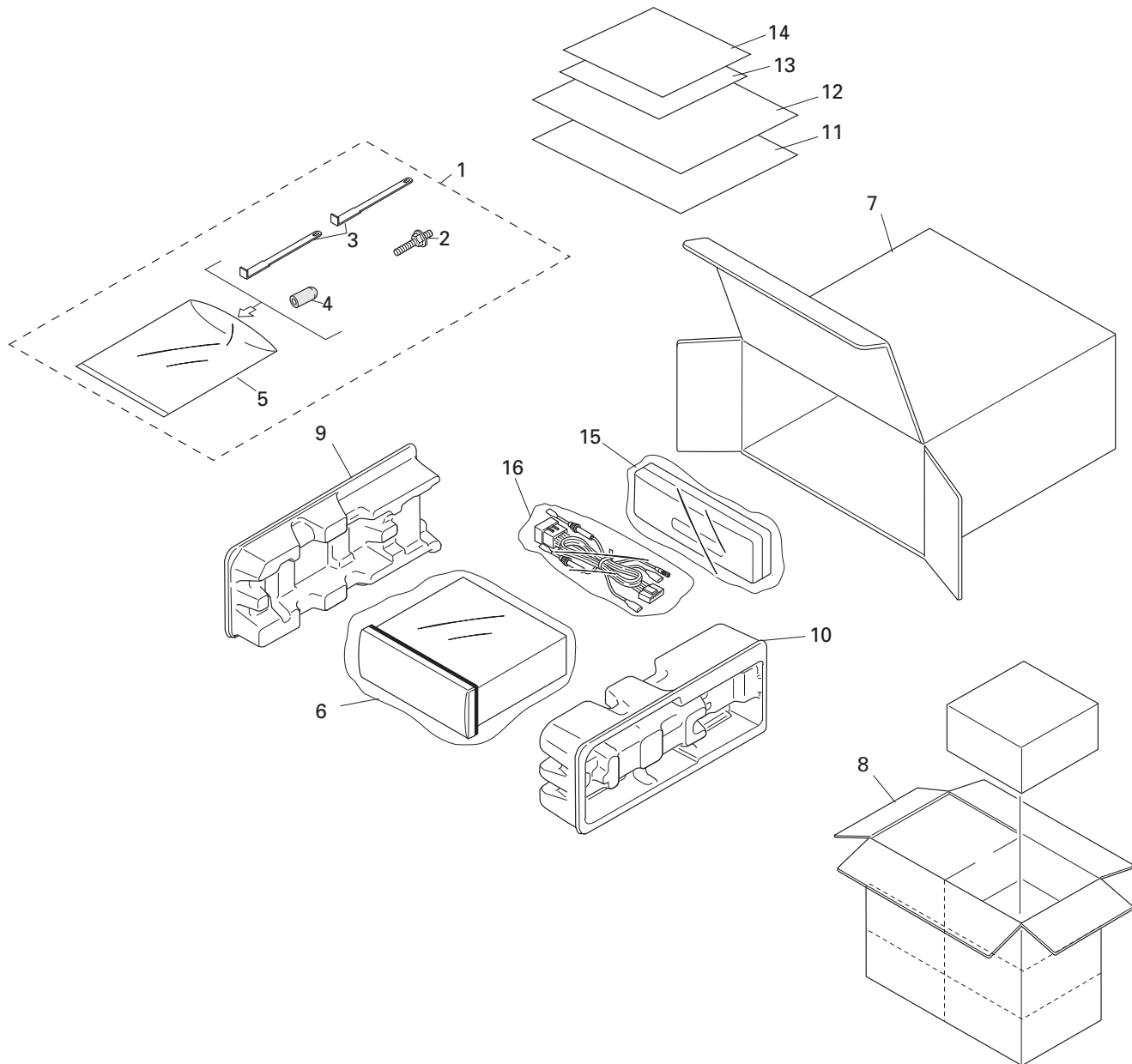

NOTE:

- Parts marked by "*" are generally unavailable because they are not in our Master Spare Parts List.
- Screws adjacent to ∇ mark on the product are used for disassembly.

● PACKING SECTION PARTS LIST

Mark No.	Description	Part.No	
		KEH-1940/X1M/EW	KEH-1960/X1M/EW
	1 Accessory Assy	CEA1917	CEA1917
	2 Screw	CBA1304	CBA1304
	3 Handle	CNC5395	CNC5395
	4 Bush	CNV3930	CNV3930
*	5 Polyethylene Bag	E36-615	E36-615
	6 Polyethylene Bag	CEG-162	CEG-162
	7 Carton	CHG3911	CHG3912
	8 Contain Box	CHL3911	CHG3912
	9 Protector	CHP1622	CHP1622
	10 Protector	CHP1623	CHP1623
	11 Owner's Manual	CRD3094	CRD3094
	12 Installation Manual	CRD3096	CRD3096
*	13 Passport	CRY1013	CRY1013
*	14 Warranty Card	CRY1157	CRY1157
	15 Case Assy	CXB3520	CXB3520
	16 Cord Assy	CDE6212	CDE6212

● Owner's Manual

Model	Part No.	Language
KEH-1940/X1M/EW	CRD3094	English, Spanish, German, French, Italian, Dutch
KEH-1960/X1M/EW		

● Installation Manual

Model	Part No.	Language
KEH-1940/X1M/EW	CRD3096	English, Spanish, German, French, Italian, Dutch
KEH-1960/X1M/EW		

2.2 EXTERIOR

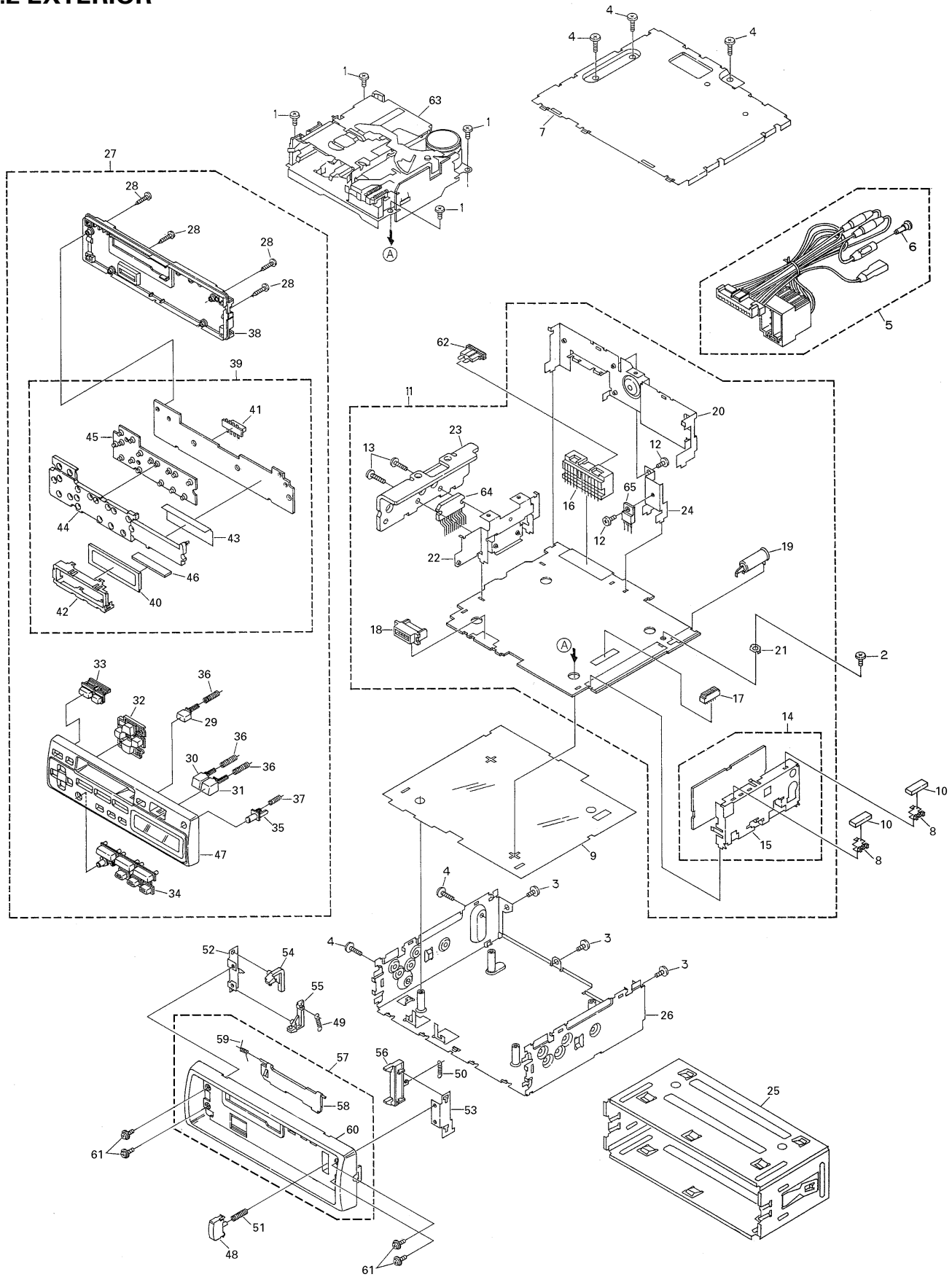

(1) EXTERIOR SECTION PARTS LIST

Mark No.	Description	Part No.	Mark No.	Description	Part No.
1	Screw	BSZ26P050FMC	36	Spring	CBH1836
2	Screw	BSZ30P055FUC	37	Spring	CBH2307
3	Screw	BSZ30P060FMC	38	Cover	See Contrast table(2)
4	Screw	BSZ30P100FMC	39	Keyboard Unit	See Contrast table(2)
5	Cord Assy	CDE6212	40	LCD(LCD901)	CAW1568
6	Cap	CKX-003	41	Connector(CN901)	CKS3580
7	Case	CNB2481	42	Holder	CNC8525
8	Holder	CNC5704	43	Sheet	CNM6486
9	Insulator	CNM5025	44	Lighting Conductor	CNV5969
10	Cushion	CNM5210	45	Rubber	CNV5970
11	Tuner Amp Unit	CWM6740	46	Connector	CNV5972
12	Screw	BSZ26P080FMC	47	Grille Unit	See Contrast table(2)
13	Screw	BSZ26P140FMC	48	Button	CAC4836
14	FM/AM Tuner Unit	CWE1466	49	Spring	CBH1834
15	Holder	CNC6554	50	Spring	CBH1835
16	Plug(CN603)	CKM1270	51	Spring	CBH2367
17	Connector(CN601)	CKS3362	52	Bracket	CNC6135
18	Connector(CN602)	CKS3581	53	Bracket	CNC6791
19	Antenna Jack(CN301)	CKX1056	54	Arm	CNV4692
20	Panel	CNB2246	55	Arm	CNV4693
21	Holder	CNC5399	56	Arm	CNV4728
22	Holder	CNC6216	57	Panel Unit	See Contrast table(2)
23	Heat Sink	CNC6217	58	Door	See Contrast table(2)
24	Holder	CNC6845	59	Spring	CBH1838
25	Holder Unit	CXB2687	60	Panel	See Contrast table(2)
26	Chassis Unit	See Contrast table(2)	61	Screw	IMS20P030FZK
27	Detach Grille Assy	See Contrast table(2)	62	Fuse(10A)	CEK1136
28	Screw	BPZ20P120FZK	63	Cassette Mechanism Assy	EXK3410
29	Button(EJECT)	See Contrast table(2)	64	IC(IC501)	TDA7384
30	Button(REW)	See Contrast table(2)	65	Transistor(Q804)	2SD2395
31	Button(FF)	See Contrast table(2)			
32	Button(CROSS)	See Contrast table(2)			
33	Button(TUNER/BAND)	See Contrast table(2)			
34	Button(1-6)	CAC6300			
35	Button(DETACH)	See Contrast table(2)			

KEH-1940,1960

(2) CONTRAST TABLE

KEH-1940/X1M/EW and KEH-1960/X1M/EW are constructed the same except for the following:

Mark	No.	Description	Part No.	
			KEH-1940/X1M/EW	KEH-1960/X1M/EW
	26	Chassis Unit	CXB4636	CXB4637
	27	Detach Grille Assy	CXB4671	CXB4672
	29	Button(EJECT)	CAC5870	CAC5871
	30	Button(REW)	CAC5872	CAC5873
	31	Button(FF)	CAC5874	CAC5875
	32	Button(CROSS)	CAC6295	CAC6296
	33	Button(TUNER/BAND)	CAC6297	CAC6298
	35	Button(DETACH)	CAC6301	CAC6302
	38	Cover	CNS5696	CNS5697
	39	Keyboard Unit	CWM6745	CWM6746
	47	Grille Unit	CXB4631	CXB4632
	57	Panel Unit	CXB4924	CXB4925
	58	Door	CAT2109	CAT2108
	60	Panel	CNS5211	CNS5212

2.3 CASSETTE MECHANISM ASSY

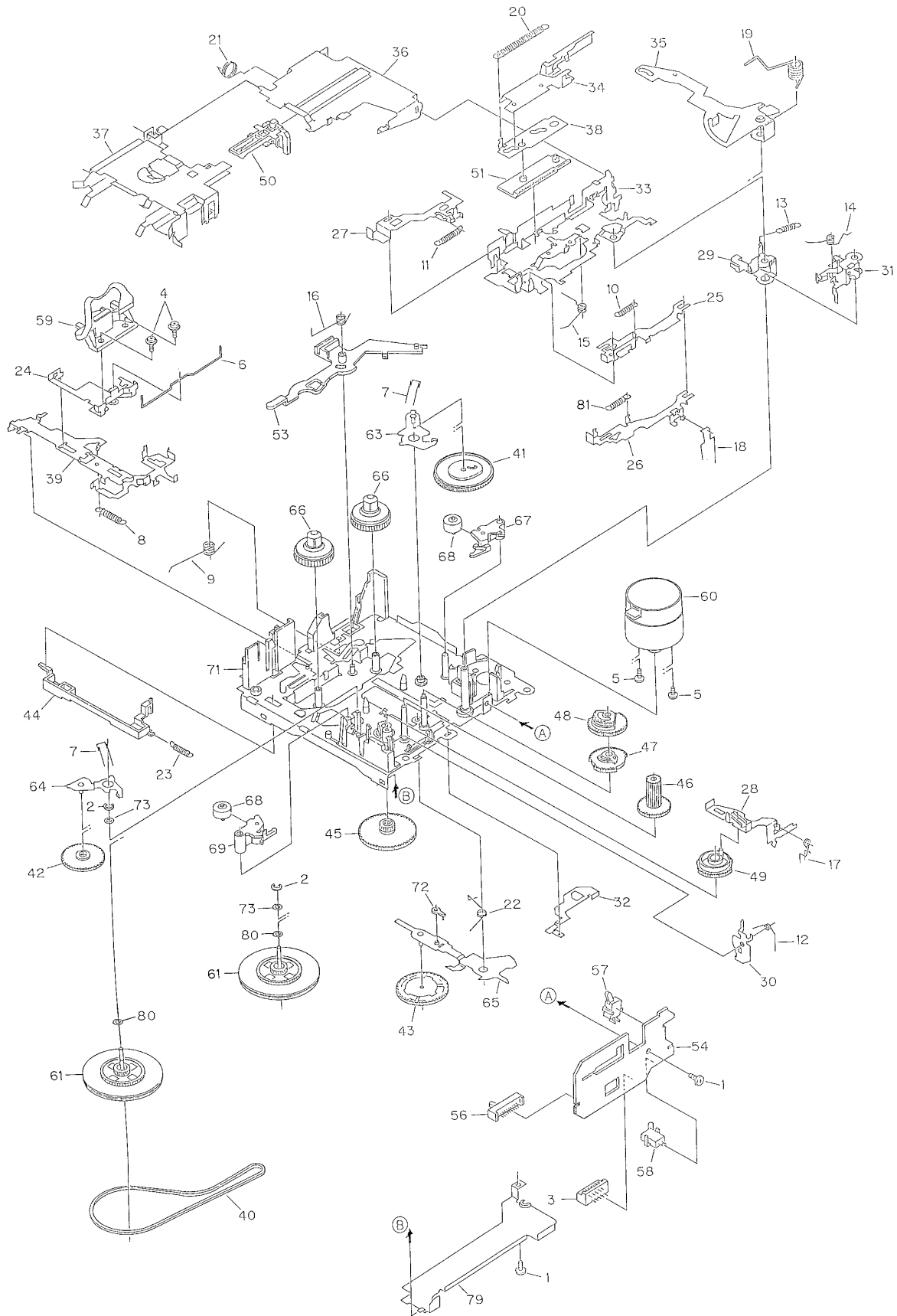

● CASSETTE MECHANISM ASSY SECTION PARTS LIST

Mark No.	Description	Part No.	Mark No.	Description	Part No.
1	Screw	BSZ23P050FMC	46	Gear	ENV1475
2	Washer	CBG1003	47	Gear	ENV1512
3	Connector(CN1)	CKS2829	48	Gear	ENV1513
4	Screw(M2x5)	EBA1038	49	Gear	ENV1502
5	Screw(M2x2.5)	EBA1037	50	Lever	ENV1480
6	Spring	EBH1554	51	Lever	ENV1487
7	Spring	EBH1555	52	
8	Spring	EBH1556	53	Arm	ENV1519
9	Spring	EBH1603	* 54	PCB	ENP1161
10	Spring	EBH1591	55	
11	Spring	EBH1559	56	Switch(FWD)(REV)(S3)	ESH1006
12	Spring	EBH1593	57	Switch(Load)(S1)	ESN1016
13	Spring	EBH1561	58	Switch(Mute)(S2)	ESN1017
14	Spring	EBH1562	59	Head Assy(HD1)	EXA1466
15	Spring	EBH1563	60	Motor Unit(M1)	EXA1467
16	Spring	EBH1623	61	Flywheel Unit	EXA1547
17	Spring	EBH1565	62	
18	Spring	EBH1566	63	Arm Unit	EXA1447
19	Spring	EBH1567	64	Arm Unit	EXA1448
20	Spring	EBH1568	65	Arm Unit	EXA1534
21	Spring	EBH1569	66	Reel Unit	EXA1450
22	Spring	EBH1571	67	Pinch Holder	ENV1466
23	Spring	EBH1579	68	Pinch Roller	ENV1518
24	Head Base	ENC1475	69	Pinch Holder	ENV1467
25	Lever	ENC1429	70	
26	Lever	ENC1430	71	Chassis Unit	EXA1498
27	Lever	ENC1431	72	Arm	ENV1524
28	Lever	ENC1432	73	Washer	HBF-167
29	Arm	ENC1433	74-78	
30	Arm	ENC1434	79	Cover	ENC1452
31	Arm	ENC1480	80	Washer	CBF1051
32	Arm	ENC1493	81	Spring	EBH1592
33	Bracket	ENC1477			
34	Lever	ENC1483			
35	Arm	ENC1524			
36	Frame	ENC1440			
37	Holder	ENC1441			
38	Lever	ENC1446			
39	Lever	ENC1478			
40	Belt	ENT1027			
41	Gear	ENV1504			
42	Gear	ENV1470			
43	Gear	ENV1471			
44	Lever	ENV1472			
45	Gear	ENV1510			

3. BLOCK DIAGRAM AND SCHEMATIC DIAGRAM

3.1 BLOCK DIAGRAM

A TUNER AMP UNIT

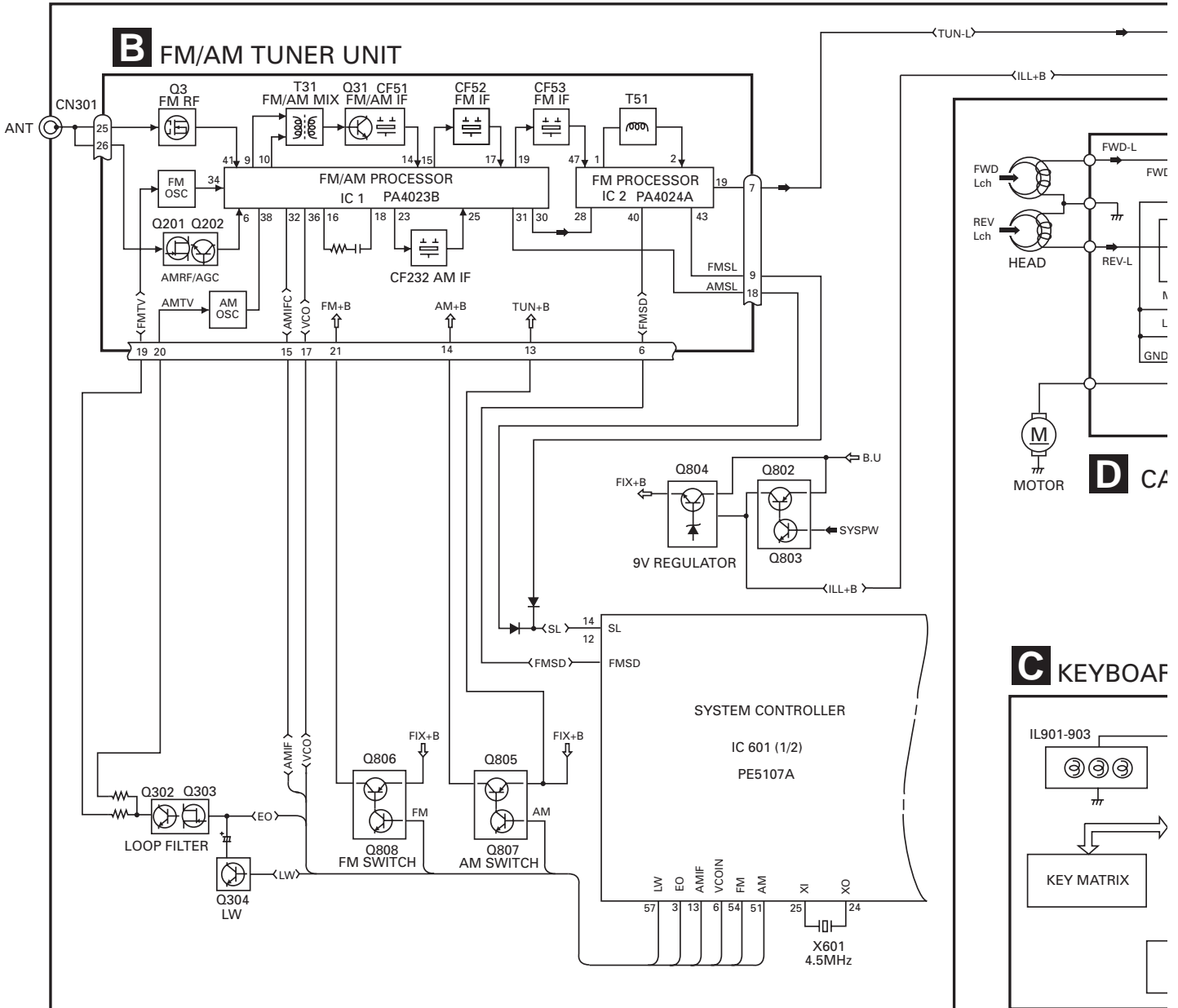

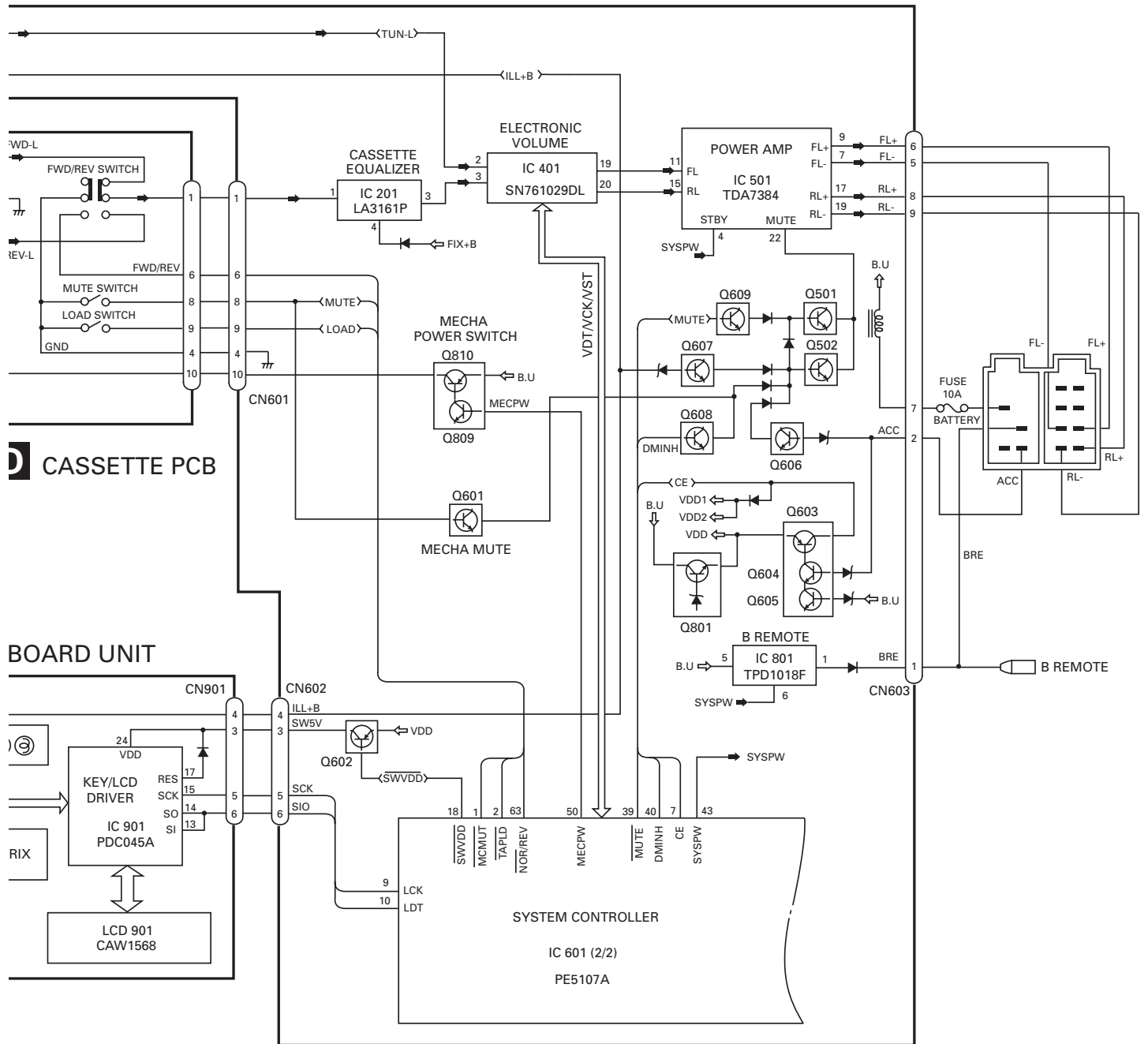

A
B
C
D

3.2 OVERALL CONNECTION DIAGRAM(GUIDE PAGE)

Note: When ordering service parts, be sure to refer to "EXPLODED VIEWS AND PARTS LIST" or "ELECTRICAL PARTS LIST".

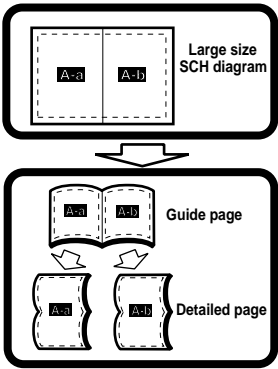

A TUNER AMP UNIT

A-a

B FM/AM TUNER UNIT

ELECTRONIC VC

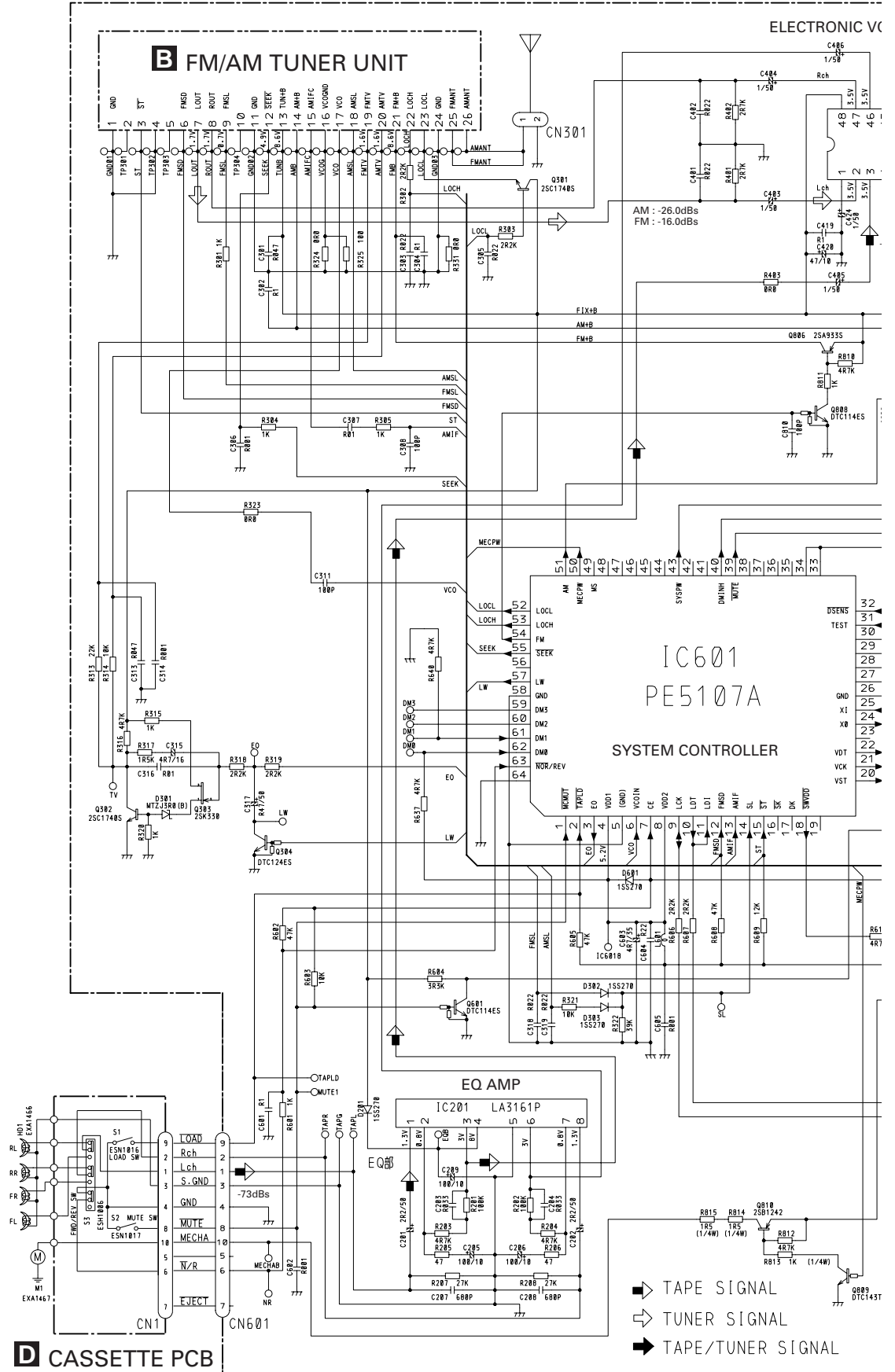

D CASSETTE PCB

- ▶ TAPE SIGNAL
- ◀ TUNER SIGNAL
- ➡ TAPE/TUNER SIGNAL

A-b

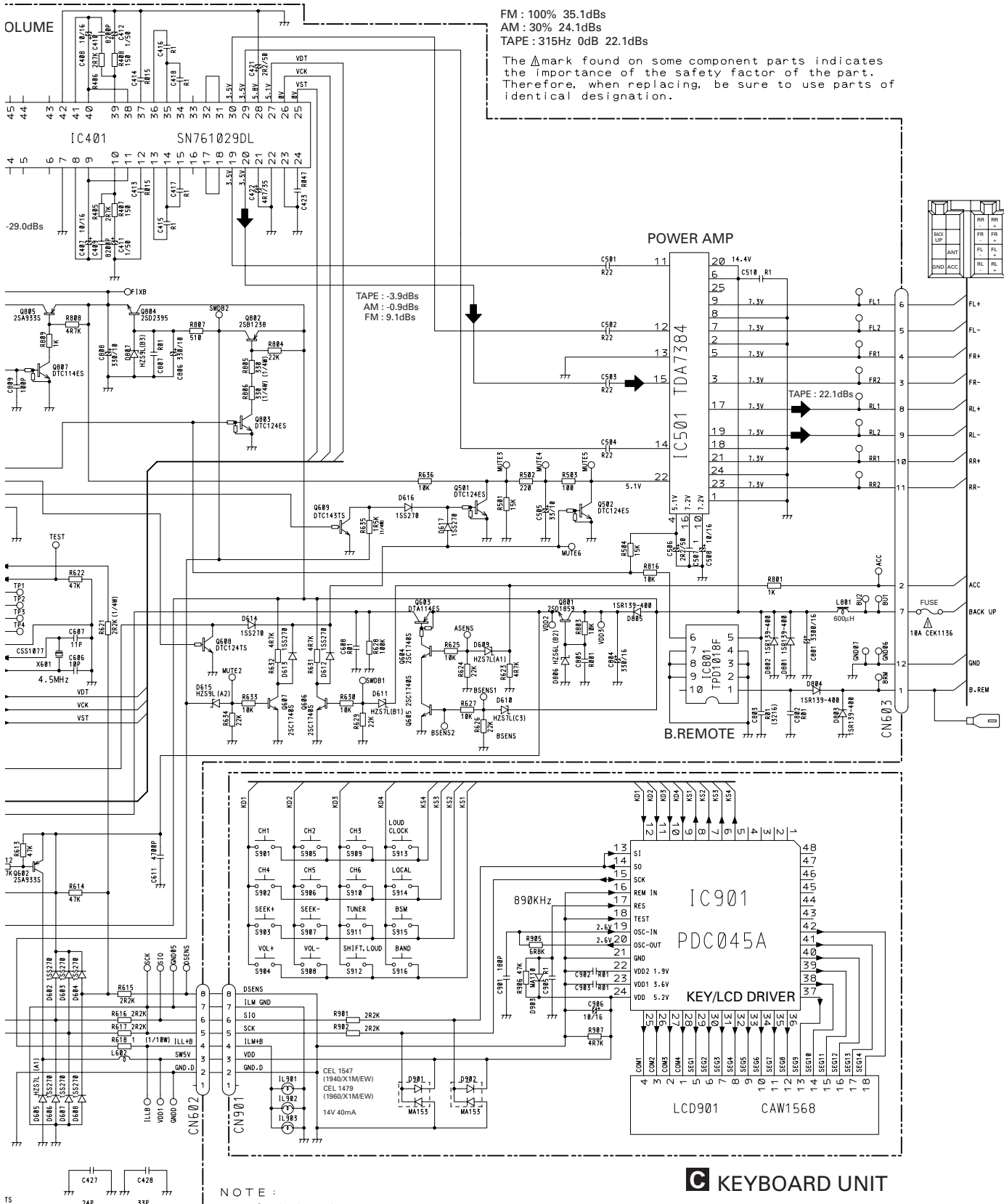

NOTE :

- Symbol indicates a resistor. No differentiation is made between chip resistors and discrete resistors.
- ⊖ Symbol indicates a capacitor. No differentiation is made between chip capacitors and discrete capacitors.

C KEYBOARD UNIT

Decimal points for resistor and capacitor fixed values are expressed as:
 2.2→2R2
 0.022→R022



A TUNER AMP UNIT

B FM/AM TUNER UNIT

ELECTRONIC VOLUME

A-a A-b

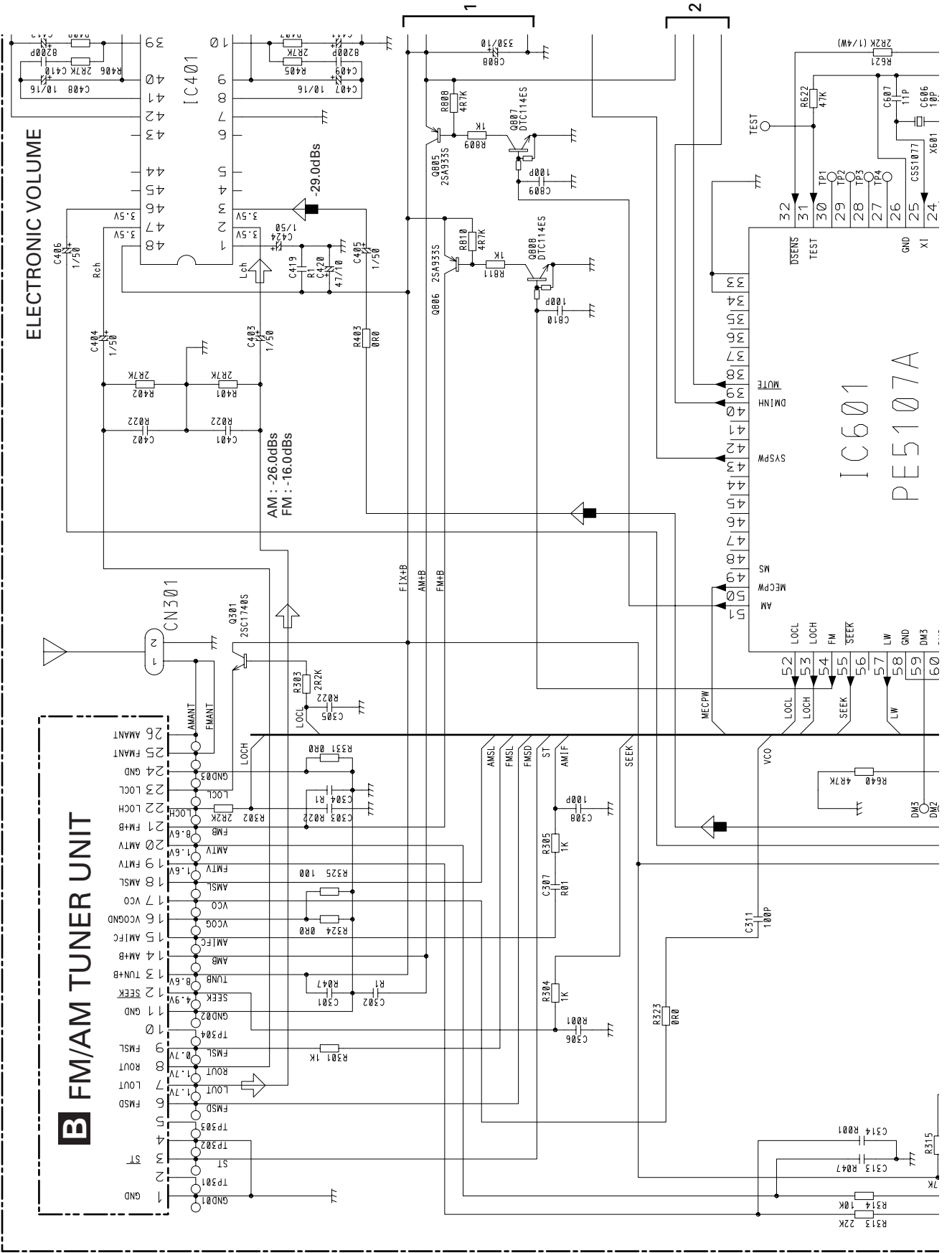

A

B

C

D

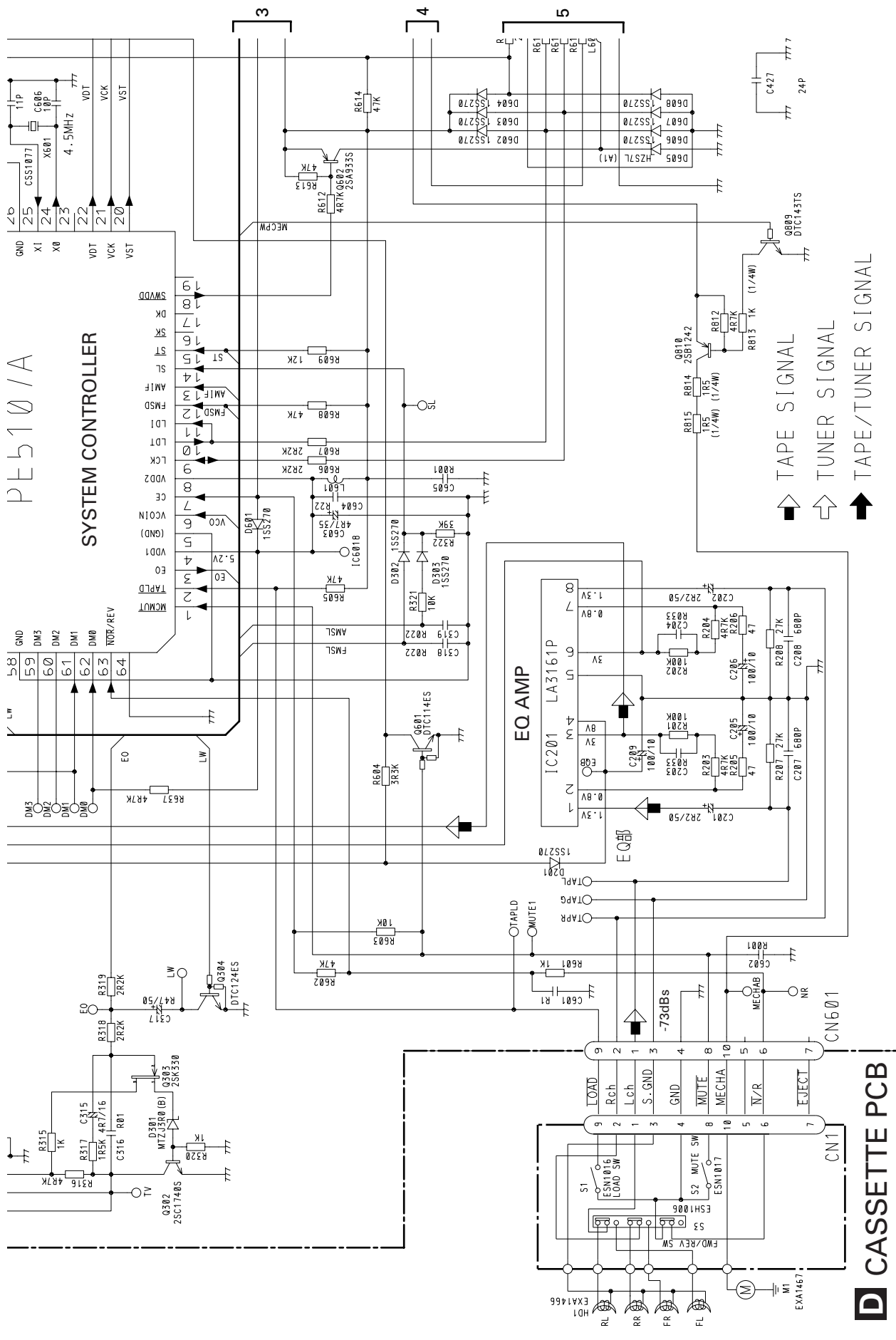

PE510/A

SYSTEM CONTROLLER

EQ AMP

CASSETTE PCB

TAPE SIGNAL
 TUNER SIGNAL
 TAPE/TUNER SIGNAL

A-a A-b

A-a

D

A-a A-b

FM : 100% 35.1dBs
 AM : 30% 24.1dBs
 TAPE : 315Hz 0dB 22.1dBs

The Δ mark found on some component parts indicates the importance of the safety factor of the part. Therefore, when replacing, be sure to use parts of identical designation.

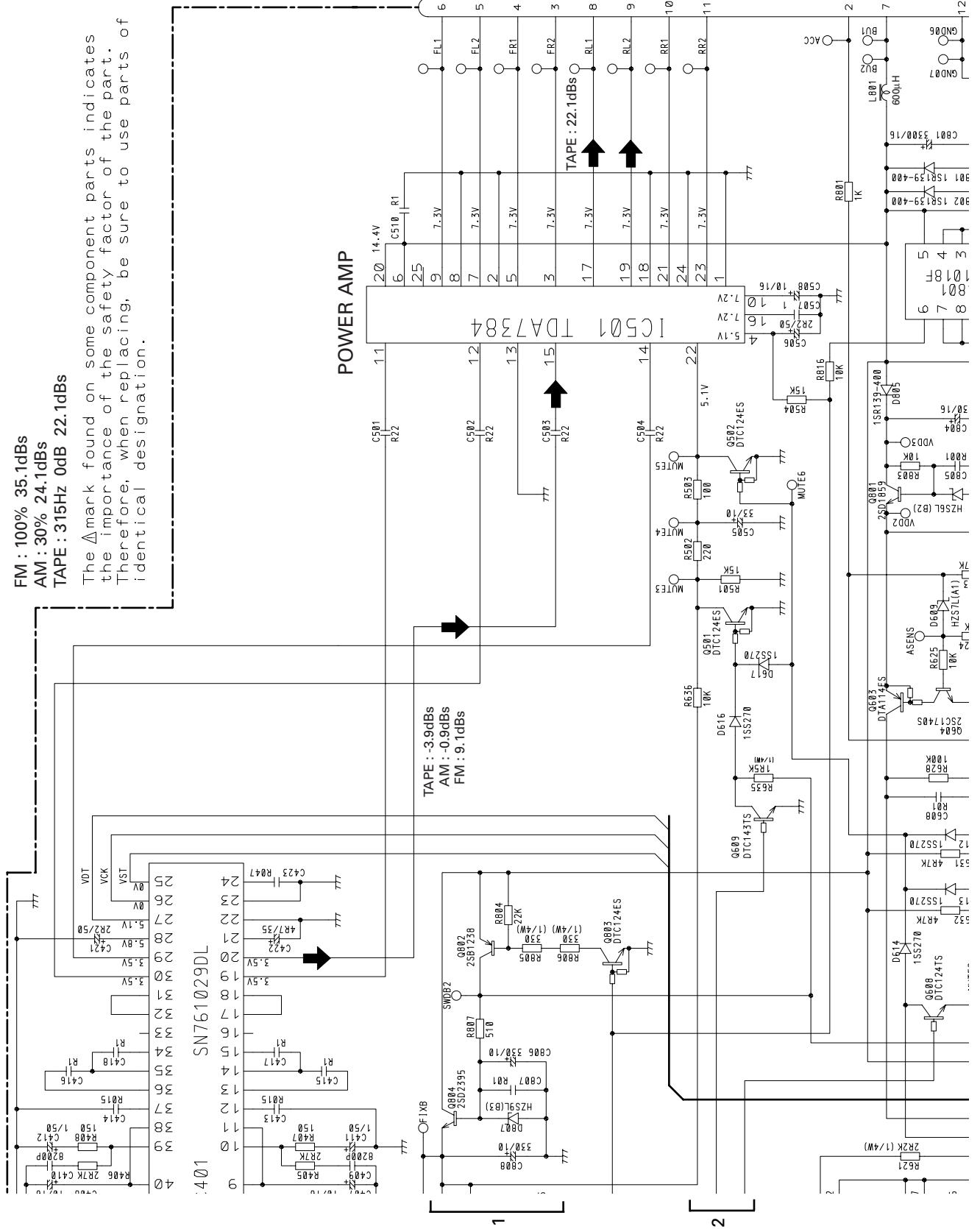
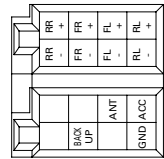

A-b

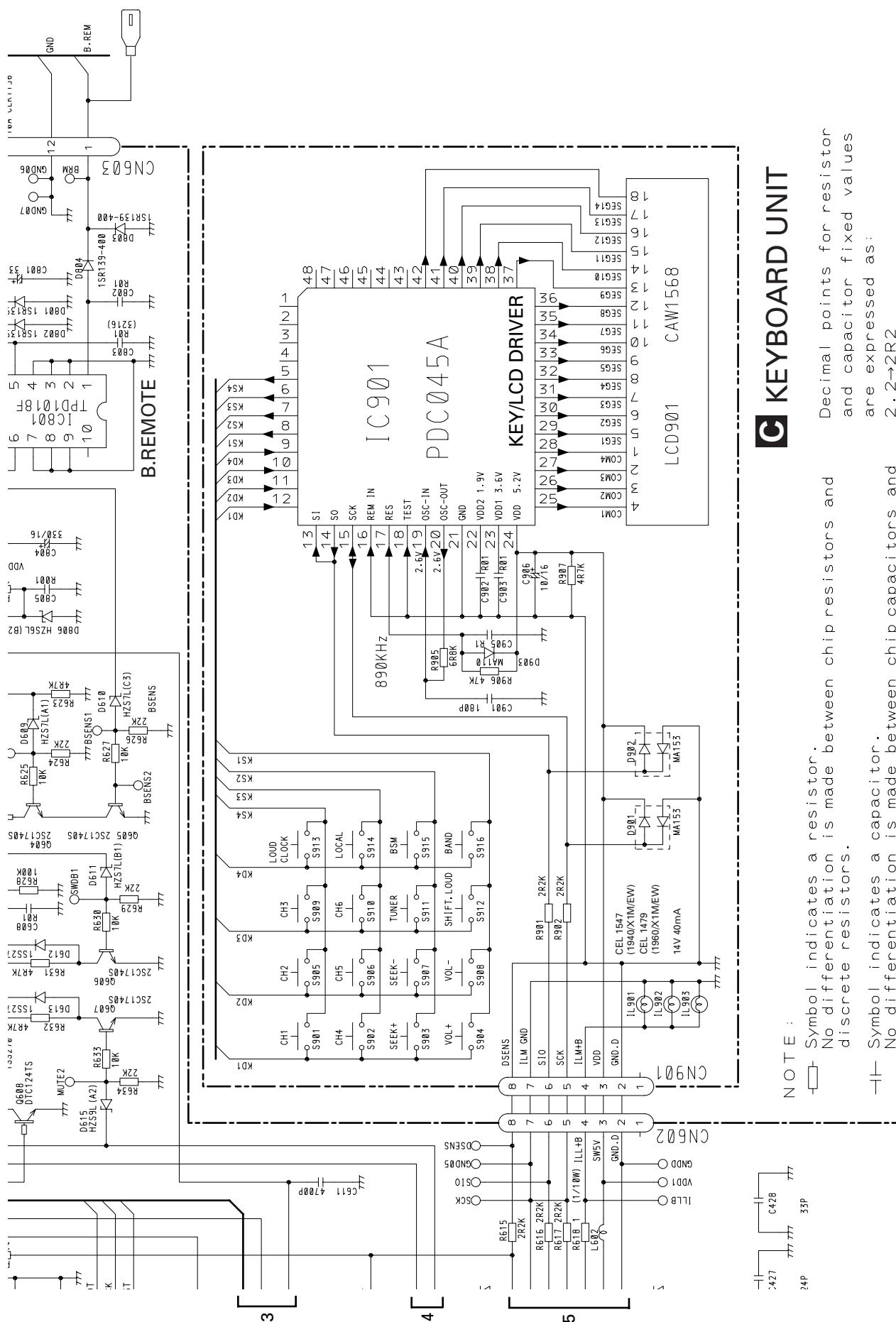

KEYBOARD UNIT

NOTE :

- Symbol indicates a resistor. No differentiation is made between chip resistors and discrete resistors.
- Symbol indicates a capacitor. No differentiation is made between chip capacitors and discrete capacitors.

Decimal points for resistor and capacitor fixed values are expressed as:
 2.2→2R2
 0.022→R022

3.3 FM/AM TUNER UNIT

B FM/AM TUNER UNIT

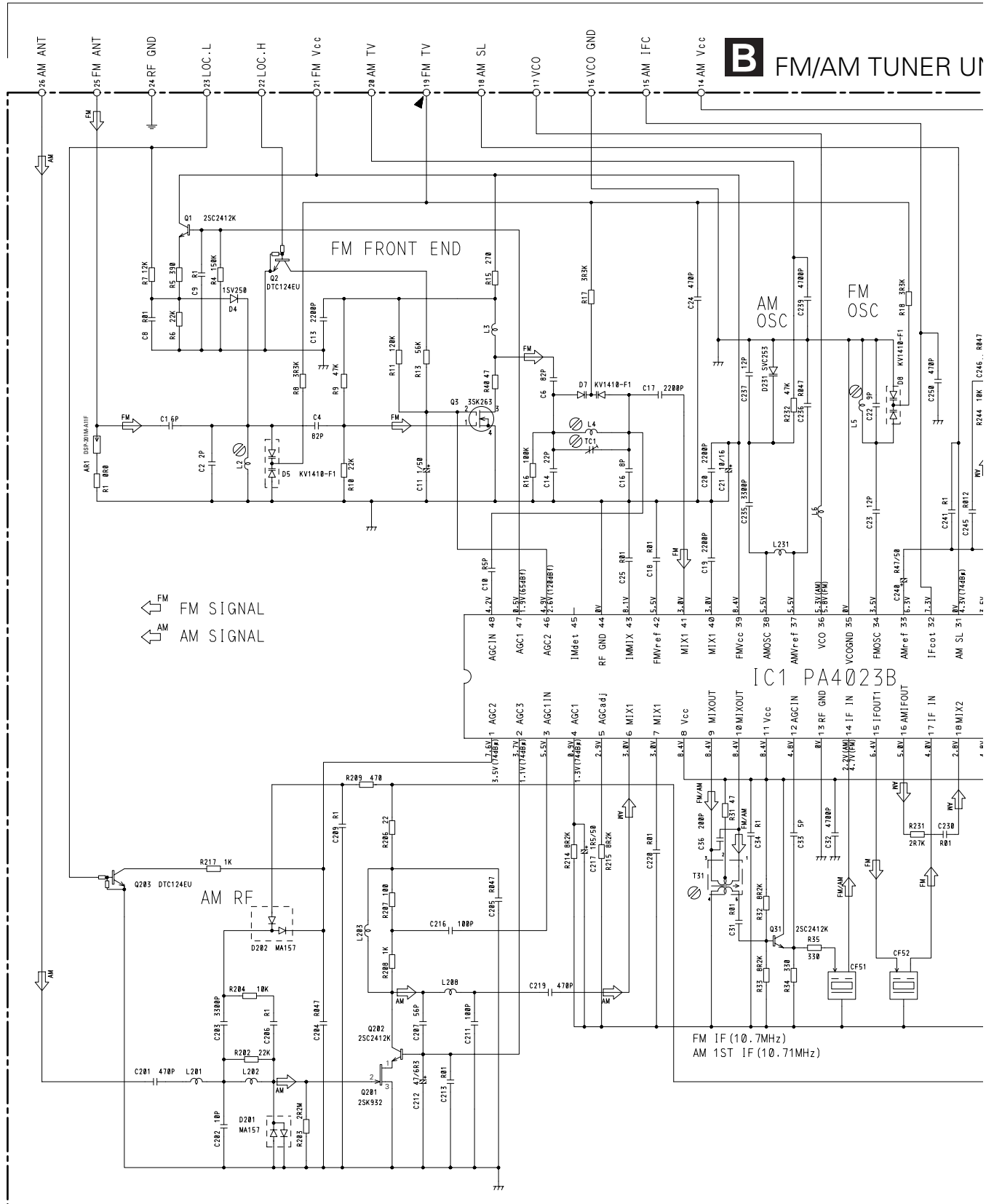

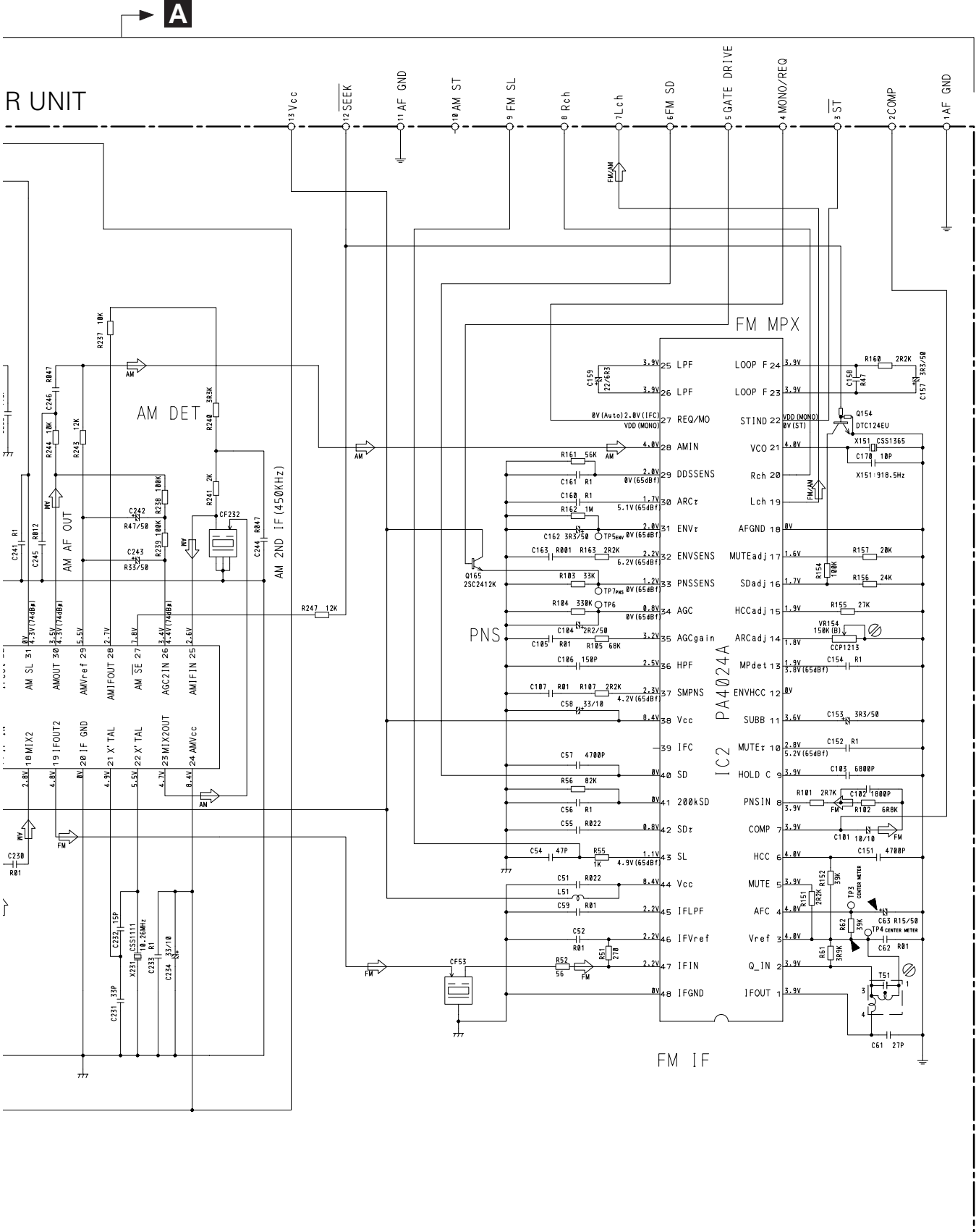

A TUNER AMP UNIT

A

B

C

D

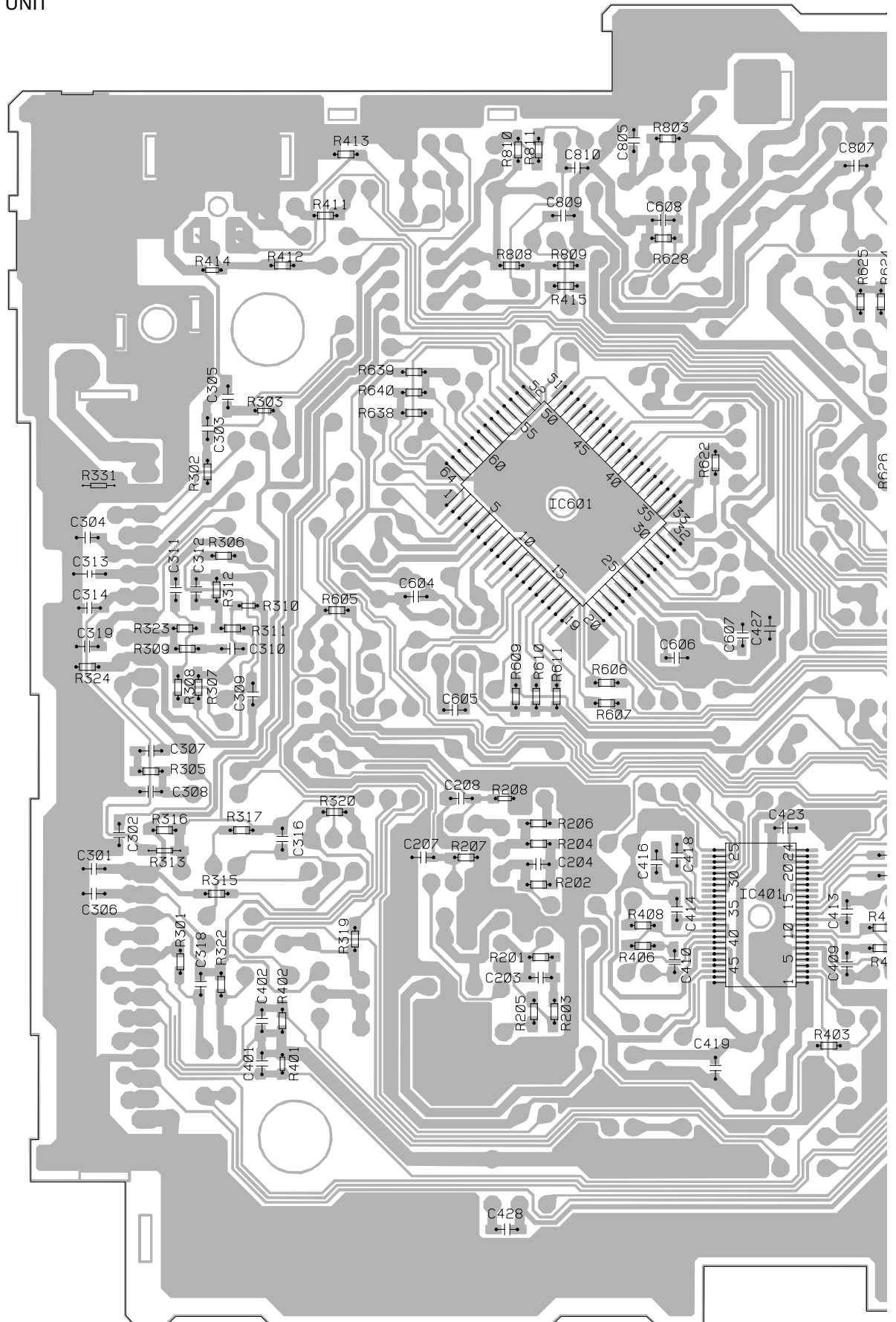

SIDE B

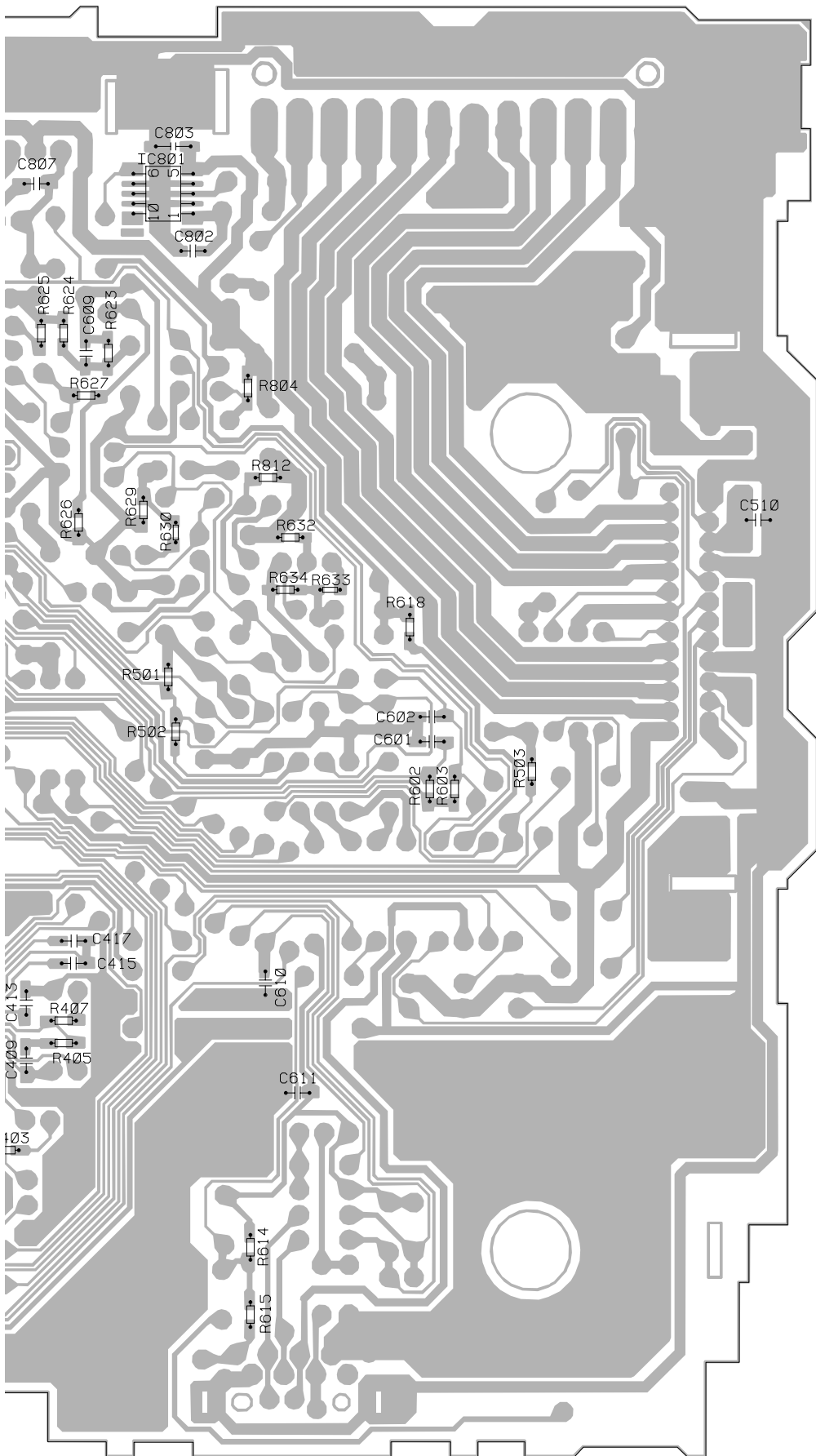

IC. Q

IC801

IC601

IC401

A

B

C

D

A

4.2 FM/AM TUNER UNIT

B FM/AM TUNER UNIT

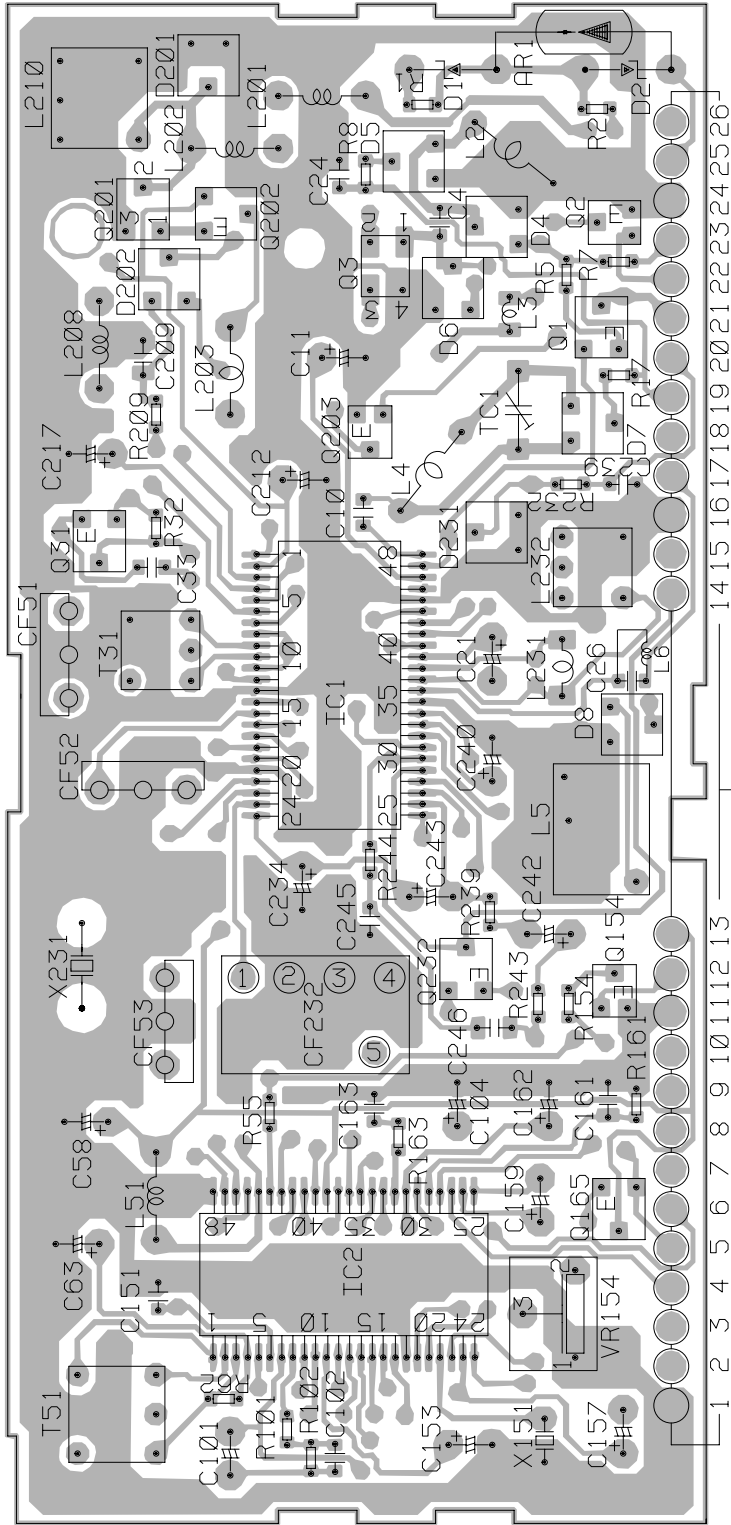

SIDE A

- | | |
|---------|-------|
| IC, Q | ADJ |
| Q31 | T51 |
| Q201 | T31 |
| Q202 | |
| Q203 Q3 | L4 |
| IC2 IC1 | L2 |
| Q232 | TC1 |
| Q1 | L5 |
| Q165 Q2 | VR154 |
| Q154 | |



SIDE B

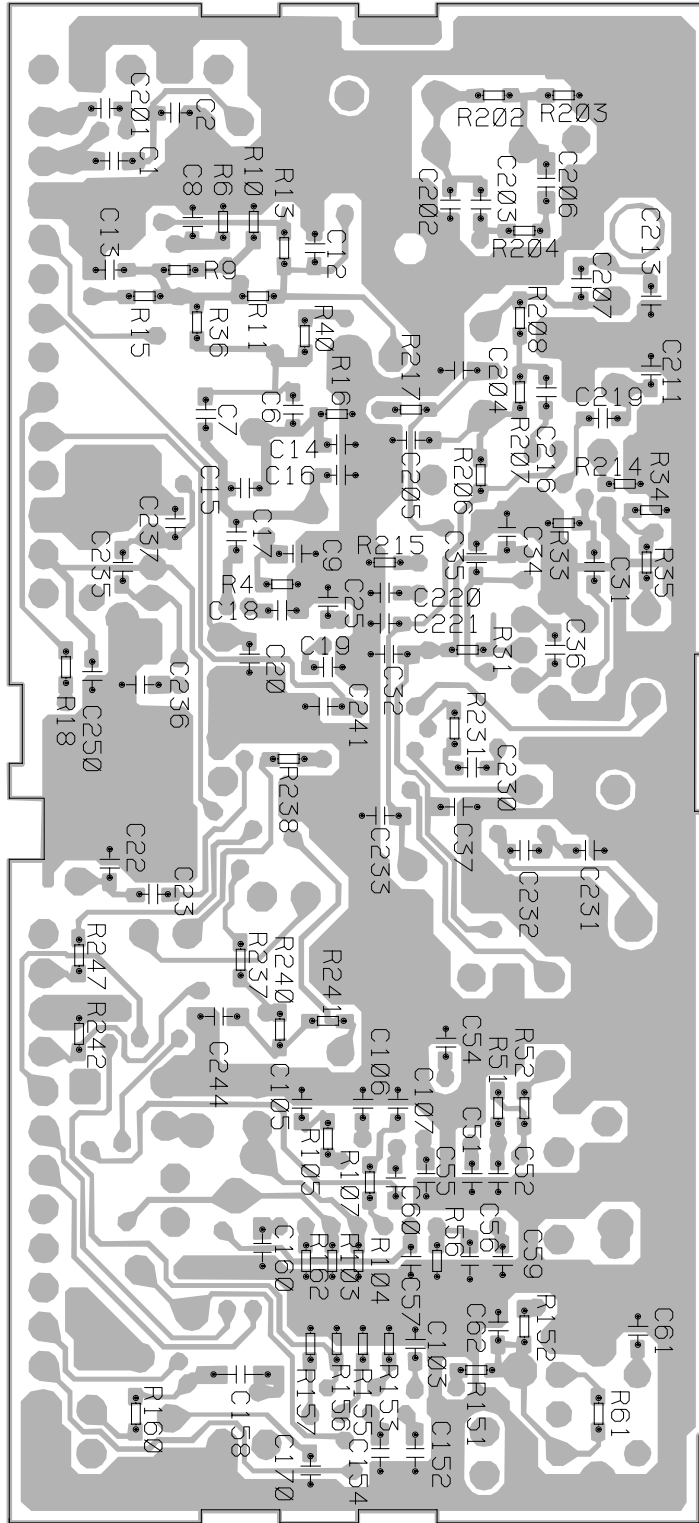

B FM/AM TUNER UNIT

4.3 KEYBOARD UNIT

SIDE A

SIDE B

C KEYBOARD UNIT

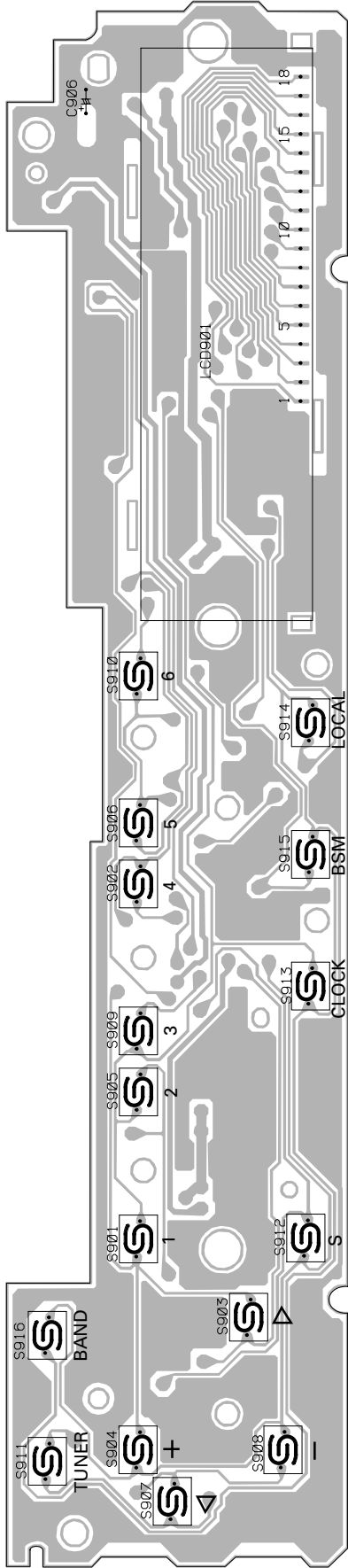

C KEYBOARD UNIT

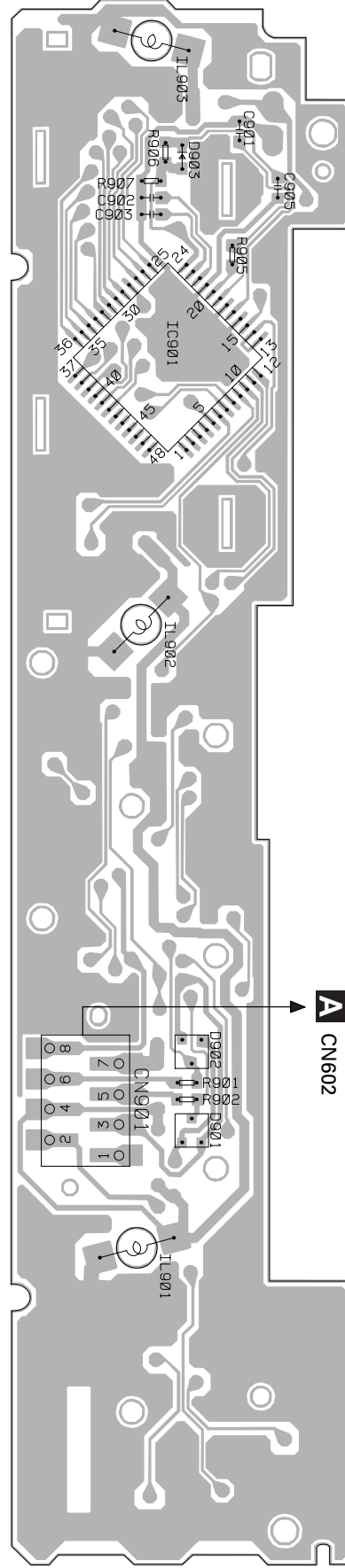

IC901

IC. 0

4.4 CASSETTE PCB

D CASSETTE PCB

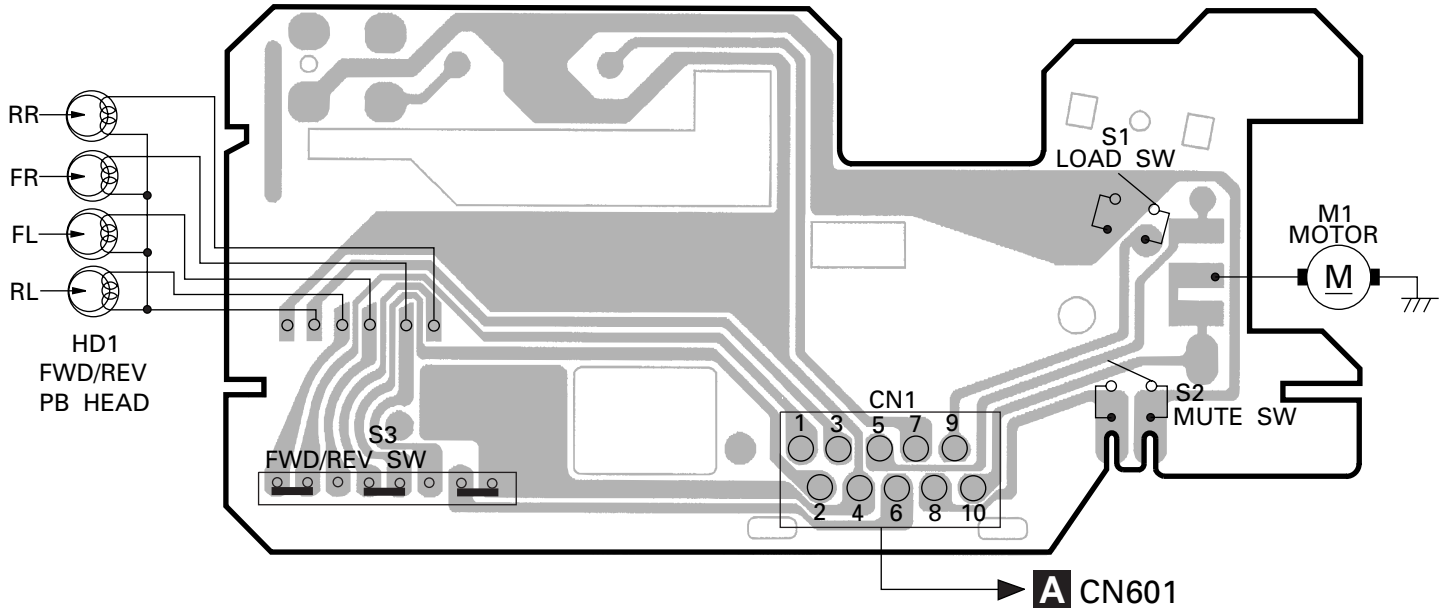

5. ELECTRICAL PARTS LIST

NOTE:

● Parts whose parts numbers are omitted are subject to being not supplied.

● The part numbers shown below indicate chip components.

Chip Resistor

RS1/OSOOOJ,RS1/OOSOOOJ

Chip Capacitor (except for CQS.....)

CKS....., CCS....., CSZS.....

====Circuit Symbol and No.====Part Name	Part No.	====Circuit Symbol and No.====Part Name	Part No.
A Unit Number : CWM6740		D 617 Diode	1SS270
Unit Name : Tuner Amp Unit		D 801 Diode	1SR139-400
MISCELLANEOUS		D 802 Diode	1SR139-400
IC 201 IC	LA3161P	D 803 Diode	1SR139-400
IC 401 IC	SN761029DL	D 804 Diode	1SR139-400
IC 501 IC	TDA7384	D 805 Diode	1SR139-400
IC 601 IC	PE5107A	D 806 Diode	HZS6L(B2)
IC 801 IC	TPD1018F	D 807 Diode	HZS9L(B3)
		L 601 Ferri-Inductor	LAU2R2K
		L 602 Ferri-Inductor	LAU2R2K
Q 301 Transistor	2SC1740S	L 801 Choke Coil 600µH	CTH1168
Q 302 Transistor	2SC1740S	X 601 Crystal Resonator 4.500MHz	CSS1077
Q 303 Transistor	2SK330		CWE1466
Q 304 Transistor	DTC124ES		
Q 501 Transistor	DTC124ES	RESISTORS	
		R 201	RS1/10S104J
Q 502 Transistor	DTC124ES	R 202	RS1/10S104J
Q 601 Transistor	DTC114ES	R 203	RS1/10S472J
Q 602 Transistor	2SA933S	R 204	RS1/10S472J
Q 603 Transistor	DTA114ES	R 205	RS1/10S470J
Q 604 Transistor	2SC1740S		
		R 206	RS1/10S470J
Q 605 Transistor	2SC1740S	R 207	RS1/10S273J
Q 606 Transistor	2SC1740S	R 208	RS1/10S273J
Q 607 Transistor	2SC1740S	R 301	RS1/10S102J
Q 608 Transistor	DTC124TS	R 302	RS1/10S222J
Q 609 Transistor	DTC143TS		
		R 303	RS1/10S222J
Q 801 Transistor	2SD1859	R 304	RD1/4PU102J
Q 802 Transistor	2SB1238	R 305	RS1/10S102J
Q 803 Transistor	DTC124ES	R 313	RS1/8S223J
Q 804 Transistor	2SD2395	R 314	RD1/4PU103J
Q 805 Transistor	2SA933S		
		R 315	RS1/10S102J
Q 806 Transistor	2SA933S	R 316	RS1/10S472J
Q 807 Transistor	DTC114ES	R 317	RS1/10S152J
Q 808 Transistor	DTC114ES	R 318	RD1/4PU222J
Q 809 Transistor	DTC143TS	R 319	RS1/10S222J
Q 810 Transistor	2SB1242		
		R 320	RS1/10S102J
D 201 Diode	1SS270	R 321	RD1/4PU103J
D 301 Diode	MTZJ3R0(B)	R 322	RS1/10S393J
D 302 Diode	1SS270	R 323	RS1/10S0R0J
D 303 Diode	1SS270	R 324	RS1/10S0R0J
D 601 Diode	1SS270		
		R 325	RD1/4PU101J
D 602 Diode	1SS270	R 331	RS1/8S0R0J
D 603 Diode	1SS270	R 401	RS1/10S272J
D 604 Diode	1SS270	R 402	RS1/10S272J
D 605 Diode	HZS7L(A1)	R 403	RS1/10S0R0J
D 606 Diode	1SS270		
		R 405	RS1/10S272J
D 607 Diode	1SS270	R 406	RS1/10S272J
D 608 Diode	1SS270	R 407	RS1/10S151J
D 609 Diode	HZS7L(A1)	R 408	RS1/10S151J
D 610 Diode	HZS7L(C3)	R 501	RS1/10S153J
D 611 Diode	HZS7L(B1)		
		R 502	RS1/10S221J
D 612 Diode	1SS270	R 503	RS1/10S101J
D 613 Diode	1SS270	R 504	RD1/4PU153J
D 614 Diode	1SS270	R 601	RD1/4PU102J
D 615 Diode	HZS9L(A2)	R 602	RS1/10S473J
D 616 Diode	1SS270		

====Circuit Symbol and No.====Part Name	Part No.	====Circuit Symbol and No.====Part Name	Part No.
Q 31 Transistor	2SC2412K	R 105	RS1/16S683J
Q 154 Transistor	DTC124EU	R 107	RS1/16S222J
Q 165 Transistor	2SC2412K	R 151	RS1/16S222J
Q 201 FET	2SK932	R 152	RS1/16S393J
Q 202 Transistor	2SC2412K	R 154	RS1/16S104J
Q 203 Transistor	DTC124EU	R 155	RS1/16S273J
D 4 Diode	1SV250	R 156	RS1/16S243J
D 5 Diode	KV1410-F1	R 157	RS1/16S203J
D 7 Diode	KV1410-F1	R 160	RS1/16S222J
D 8 Diode	KV1410-F1	R 161	RS1/16S563J
D 201 Diode	MA157	R 162	RS1/16S105J
D 202 Diode	MA157	R 163	RS1/16S222J
D 231 Diode	SVC253	R 202	RS1/16S223J
L 2 Coil	CTC1133	R 203	RS1/16S225J
L 3 Inductor	LCTB2R2K2125	R 204	RS1/16S103J
L 4 Coil	CTC1133	R 206	RS1/16S220J
L 5 Coil	CTC1132	R 207	RS1/16S101J
L 6 Inductor	LCTBR15K1608	R 208	RS1/16S102J
L 51 Ferri-Inductor	LAU150K	R 209	RS1/16S471J
L 201 Ferri-Inductor	LAU4R7K	R 214	RS1/16S822J
L 202 Ferri-Inductor	LAU330K	R 215	RS1/16S822J
L 203 Inductor	CTF1287	R 217	RS1/16S102J
L 208 Inductor	LAU121K	R 231	RS1/16S272J
L 231 Inductor	LCTA3R3J3225	R 232	RS1/16S473J
T 31 Coil	CTE1116	R 237	RS1/16S103J
T 51 Coil	CTC1136	R 238	RS1/16S104J
TC 1	CCL1038	R 239	RS1/16S104J
CF 51 Ceramic Filter	CTF1442	R 240	RS1/16S332J
CF 52 Ceramic Filter	CTF1442	R 241	RS1/16S202J
CF 53 Ceramic Filter	CTF1442	R 243	RS1/16S123J
CF 232 Ceramic Filter	CTF1348	R 244	RS1/16S103J
X 151 Radiator 918.5Hz	CSS1365	R 247	RS1/16S123J
X 231 Crystal Resonator 10.26MHz	CSS1111		
VR 154 Semi-fixed 150kΩ(B)	CCP1213		
AR 1	DSP-201M-A11F		
RESISTORS		CAPACITORS	
R 1	RS1/16S0R0J	C 1	CCSQCH6R0D50
R 4	RS1/16S154J	C 2	CCSRCK2R0C50
R 5	RS1/16S391J	C 4	CCSRCH820J50
R 6	RS1/16S223J	C 6	CCSRCH820J50
R 7	RS1/16S123J	C 8	CKSRYB103K25
R 8	RS1/16S332J	C 9	CKSQYB104K16
R 9	RS1/16S473J	C 10	CCSRCKR50C50
R 10	RS1/16S223J	C 11	CEJA1R0M50
R 11	RS1/16S124J	C 13	CKSRYB222K50
R 13	RS1/16S563J	C 14	CCSRCH220J50
R 15	RS1/16S271J	C 16	CCSRCH8R0D50
R 16	RS1/16S104J	C 17	CKSRYB222K50
R 17	RS1/16S332J	C 18	CKSRYB103K25
R 18	RS1/16S332J	C 19	CKSRYB222K50
R 31	RS1/16S470J	C 20	CKSRYB222K50
R 32	RS1/16S822J	C 21	CEJA100M16
R 33	RS1/16S822J	C 22	CCSRTH9R0D50
R 34	RS1/16S331J	C 23	CCSRTH120J50
R 35	RS1/16S331J	C 24	CCSRCH471J50
R 40	RS1/16S470J	C 25	CKSRYB103K25
R 51	RS1/16S271J	C 31	CKSRYB103K25
R 52	RS1/16S560J	C 32	CKSQYB472K50
R 55	RS1/16S102J	C 33	CCSRCH5R0C50
R 56	RS1/16S823J	C 34	CKSQYB104K16
R 61	RS1/16S392J	C 36	CCSRRH201J50
R 62	RS1/16S393J	C 51	CKSRYB223K25
R 101	RS1/16S272J	C 52	CKSRYB103K25
R 102	RS1/16S682J	C 54	CCSRCH470J50
R 103	RS1/16S333J	C 55	CKSQYB223K25
R 104	RS1/16S334J	C 56	CKSQYB104K16
		C 57	CKSRYB472K50
		C 58	CEJA330M10
		C 59	CKSRYB103K25
		C 61	CCSRCH270J50
		C 62	CKSRYB103K25

====Circuit Symbol and No.====	Part Name	Part No.
C 63		CEJAR15M50
C 101		CEJANP100M10
C 102		CKSRYB182K50
C 103		CKSRYB682K25
C 104		CEJA2R2M50
C 105		CKSRYB103K25
C 106		CCSRCH151J50
C 107		CKSRYB103K25
C 151		CKSRYB472K50
C 152		CKSQYB104K16
C 153		CEJA3R3M50
C 154		CKSQYB104K16
C 157		CEJA3R3M50
C 158		CKSYB474K16
C 159		CEJA220M6R3
C 160		CKSQYB104K16
C 161		CKSQYB104K16
C 162		CEJA3R3M50
C 163		CKSRYB102K50
C 170		CCSRCH100D50
C 201		CCSRCH471J50
C 202		CCSRCH100D50
C 203		CKSRYB332K50
C 204		CKSQYB473K16
C 205		CKSQYB473K16
C 206		CKSQYB104K16
C 207		CCSRCH560J50
C 209		CKSQYB104K16
C 211		CCSRCH101J50
C 212		CEJA470M6R3
C 213		CKSRYB103K25
C 216		CCSRCH101J50
C 217		CEJA1R5M50
C 219		CCSRCH471J50
C 220		CKSRYB103K25
C 230		CKSRYB103K25
C 231		CCSRCH330J50
C 232		CCSRCH150J50
C 233		CKSQYB104K16
C 234		CEJA330M10
C 235		CKSRYB332K50
C 236		CKSQYB473K16
C 237		CCSRCH120J50
C 239		CKSRYB472K50
C 240		CEJAR47M50
C 241		CKSQYB104K16
C 242		CEJAR47M50
C 243		CEJAR33M50
C 244		CKSQYB473K16
C 245		CKSRYB123K25
C 246		CKSQYB473K16
C 250		CCSRCH471J50

C Unit Number : CWM6745
 (KEH-1940/X1M/EW)
 : CWM6746
 (KEH-1960/X1M/EW)
 Unit Name : Keyboard Unit

MISCELLANEOUS

IC 901	IC	PDC045A
D 901	Diode	MA153
D 902	Diode	MA153
D 903	Diode	MA110
IL 901	Lamp 14V 40mA (1940/X1M/EW)	CEL1547

====Circuit Symbol and No.====	Part Name	Part No.
IL 901	Lamp 14V 40mA (1960/X1M/EW)	CEL1479
IL 902	Lamp 14V 40mA (1940/X1M/EW)	CEL1547
IL 902	Lamp 14V 40mA (1960/X1M/EW)	CEL1479
IL 903	Lamp 14V 40mA (1940/X1M/EW)	CEL1547
IL 903	Lamp 14V 40mA (1960/X1M/EW)	CEL1479

LCD 901 LCD CAW1568

RESISTORS

R 901	RS1/10S222J
R 902	RS1/10S222J
R 905	RS1/10S682J
R 906	RS1/10S473J
R 907	RS1/10S472J

CAPACITORS

C 901	CCSQCH181J50
C 902	CKSQYB103K50
C 903	CKSQYB103K50
C 905	CKSQYB104K16
C 906	10µF/16V CCH1370

D Unit Number :
 Unit Name : Cassette PCB

S 1	Swich(Load)	ESN1016
S 2	Swich(Mute)	ESN1017
S 3	Swich(FWD/REV)	ESH1006

Miscellaneous Parts List

M 1	Motor Unit	EXA1467
HD 1	Head Assy	EXA1466

6. ADJUSTMENT

● Connection Diagram

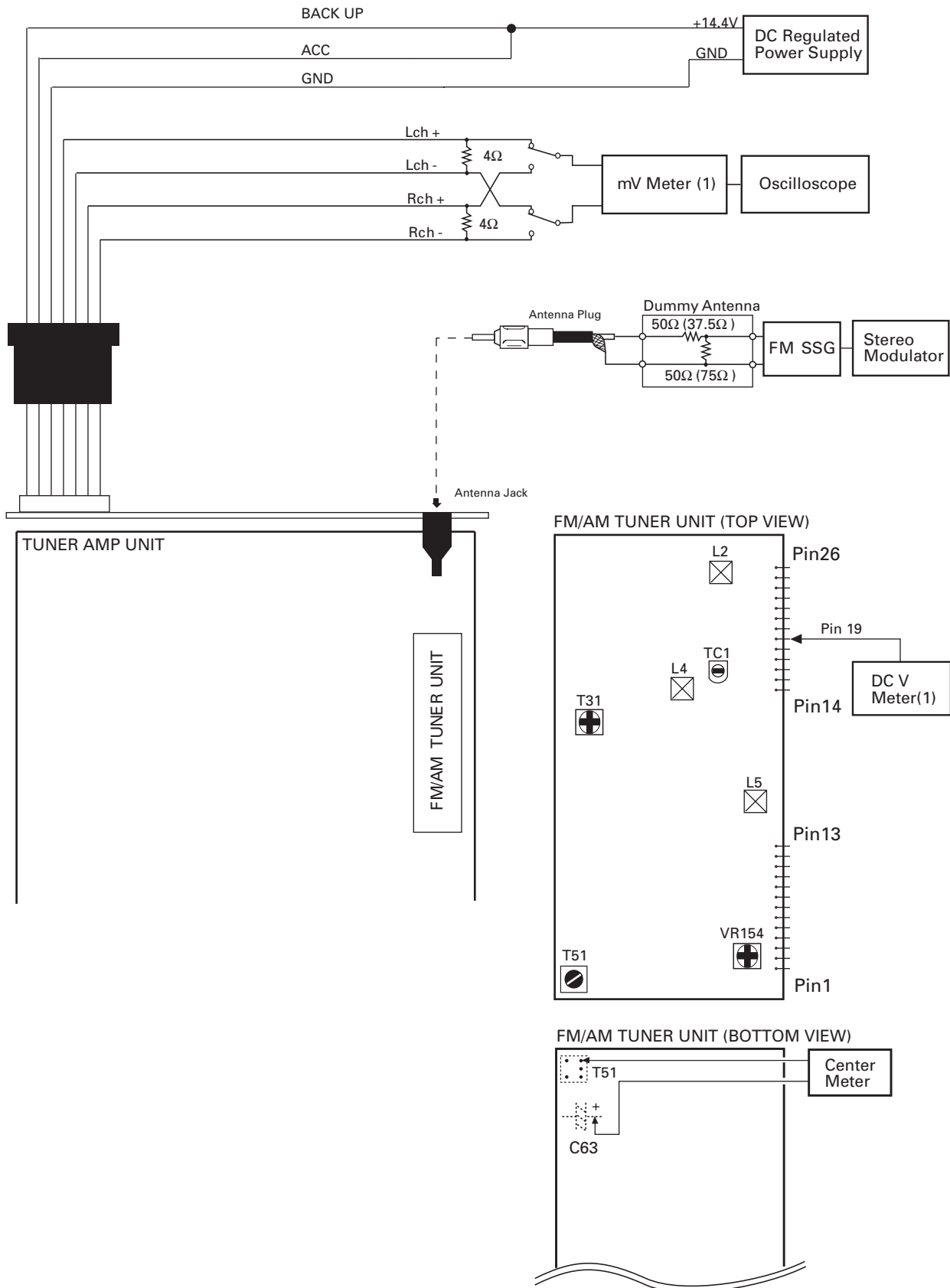

FM ADJUSTMENT

Modulation M:MONO MOD., 400Hz 30%(22.5kHz Dev.) or 400Hz 100%(75kHz Dev.)

S:STEREO MOD., 1kHz, L or R=30%(20.25kHz+7.5kHz Dev.)

NOTE:Before proceeding to further adjustments after switching power ON, let the tuner run for ten minutes to allow the circuits to stabilize.

	No.	FM SSG		Displayed Frequency(MHz)	Adjustment Point	Adjustment Method (Switch Position)
		Frequency(MHz)	Level(dBf)			
TUN Volt	1	108.0	L5	DC V Meter(1) : 6V
IF	2	98.1 M	60—100	98.1	T51	Center Meter : 0
ANT Coil	3	98.1 M	5	98.1	L2	mV Meter(1) : Maximum
RF Coil	4	98.1 M	5	98.1	L4	mV Meter(1) : Maximum
RF Trimmer	5	129.3 M	60—80	107.9	TC1	mV Meter(1) : Minimum
	6	RF Coil and RF Trimmer shall be adjusted twice or more				
IFT	7	98.1 M	5	98.1	T31	mV Meter(1) : Maximum (STEREO MODE)
ARC	8	98.1 S	40	98.1	VR154	mV Meter(1) : Separation 5dB (STEREO MODE)

7. GENERAL INFORMATION

7.1 DISASSEMBLY

● **Remove the Case(not shown)**

- 1.Remove the three screws.
- 2.Remove the Case.

● **Remove the Cassette Mechanism Assy (not shown)**

- 1.Remove the four screws.
- 2.Disconnect the connector, and then remove the Cassette Mechanism Assy.

● **Remove the Panel Unit(Fig.1)**

- 1** Disengage the stopper at two locations indicated by arrow.
- 2** Remove the Panel Unit.

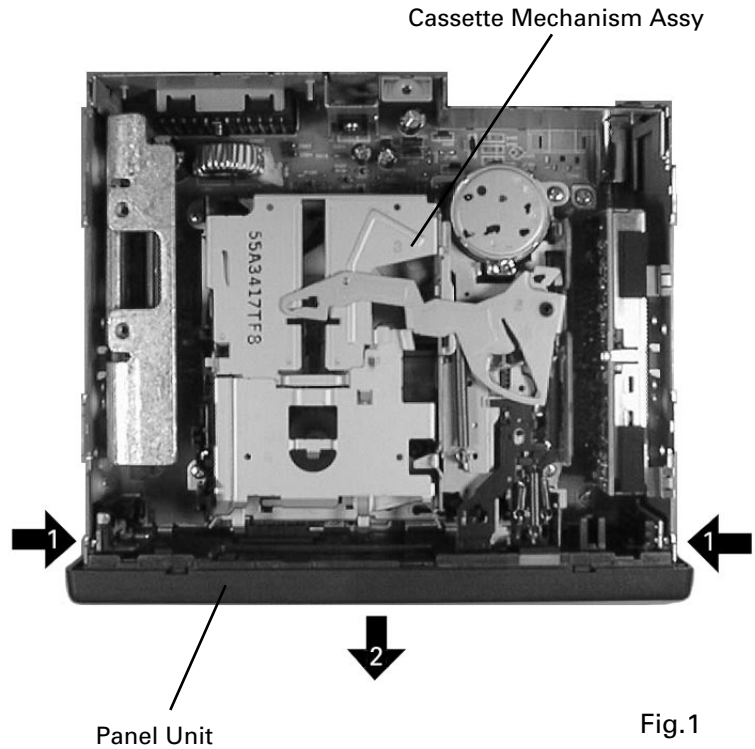

● **Remove the Tuner Amp Unit(Fig.2)**

- 1** Remove the two screws.
- 2** Remove the three screws.
- 3** Remove the screw.
- 4** Unbend the tabs at four locations indicated by arrow until straight. Remove the Tuner Amp Unit.

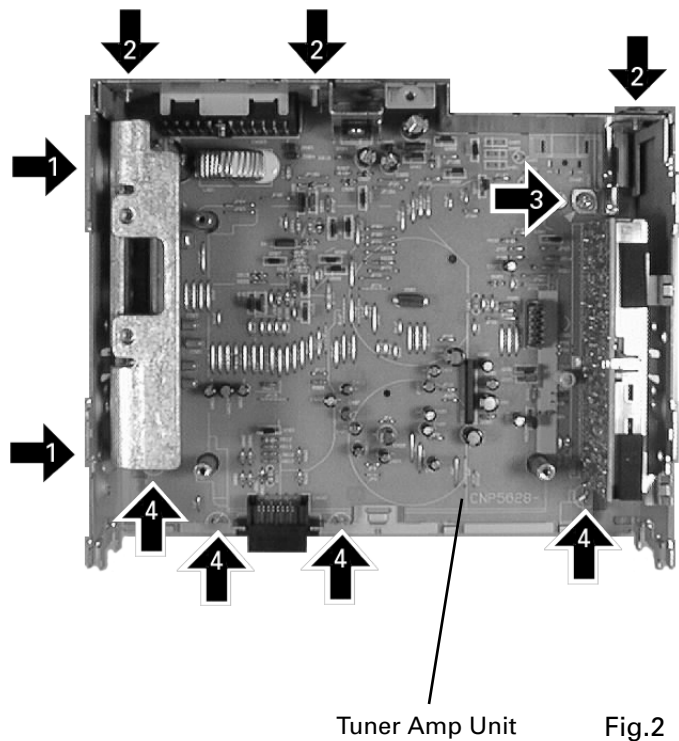

7.2 PARTS
7.2.1 IC

SN761029DL

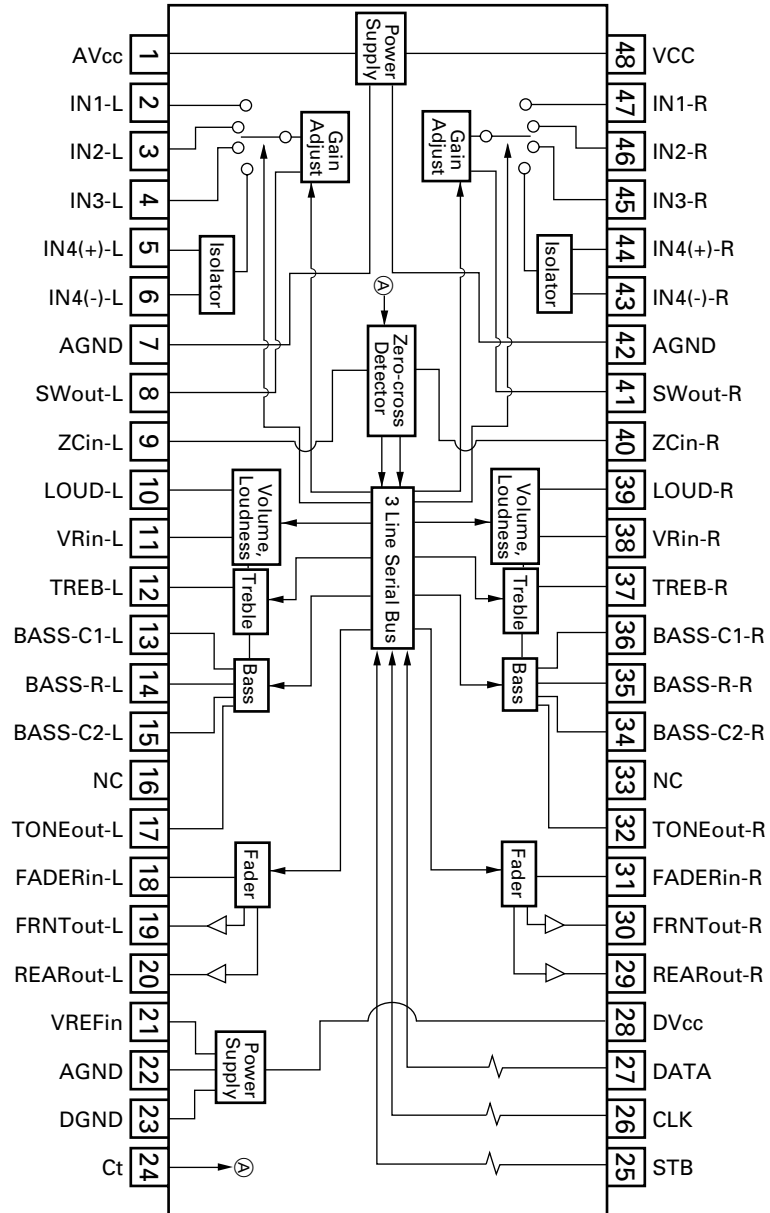

● Pin Functions (PE5107A)

Pin No.	Pin Name	I/O	Format	Function and Operation
1	MCMUTE	I		Cassette mechanism mute input
2	TAPLD	I		Tape loading input
3	EO	O	C	Error output
4	VDD1			Power supply
5	GND			GND
6	VCOIN	I		AM/FM VCO input
7	CE	I		ACC power sense input
8	VDD2			Power supply
9	LCK	I/O	C	Serial clock input and output for LCD driver
10	LDT	O	C	Data output for LCD driver
11	LDI	I		Key/LCD driver data input
12	FMSD	I		FM SD input
13	AMIF	I		AM IF signal input
14	SL	I		Signal level input
15	ST	I		FM stereo input
16	SK			Not used
17	DK			Not used
18	SWVDD	O	C	Grille power supply control output
19	NC			Not used
20	VST	O	C	Strobe pulse output for electronic volume
21	VCK	O	C	Clock output for electronic volume
22	VDT	O	C	Data output for electronic volume
23	NC			Not used
24	XO	O		Crystal oscillator connection pin
25	XI	I		Crystal oscillator connection pin
26	GND			GND
27-30	NC			Not used
31	TEST	I		Test program mode input
32	DSENS	I		Grille detach sense input
33,34	GND			GND
35-38	NC			Not used
39	MUTE	O	C	System mute output
40	DMINH	O	C	Mechanism mute cancel output
41,42	NC			Not used
43	SYSPW	O	C	System power supply control output
44-48	NC			Not used
49	MS			Not used
50	MECPW	O	C	Cassette mechanism power output
51	AM	O	C	AM power control output
52	LOCL	O	C	LOC "L" output
53	LOCH	O	C	LOC "H" output
54	FM	O	C	FM power control output
55	SEEK	O	C	Seek output
56	NC			Not used
57	LW	O	C	LW output
58	GND			GND
59	DM3			Not used
60	DM2			Not used
61	DM1	I		Model,function input
62	DM0	I		Model,function input
63	NOR/REV	I		Tape running input
64	GND			GND

*PE5107A

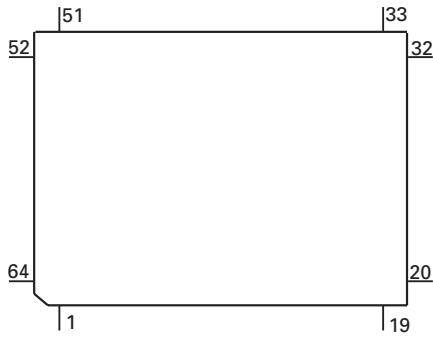

IC's marked by* are MOS type.

Be careful in handling them because they are very liable to be damaged by electrostatic induction.

Format	Meaning
C	C MOS

● Pin Functions(PDC045A)

Pin No.	Pin Name	I/O	Function and Operation
1-4	NC		Not used
5-8	KS4-1	O	Key strobe output
9-12	KD4-1	I	Key data input
13	SI	I	Display data input
14	SO	O	Key data output
15	SCK	I/O	Clock input terminal for serial data input and output
16	REMIN	I	Remote control reception
17	RES	I	Reset input
18	TEST	I	Test input
19	OSC-IN	I	System clock input
20	OSC-OUT	O	System clock output
21	GND		GND
22,23	VDD2,1		LCD power supply
24	VDD		Power supply
25-28	COM1-4	O	LCD common signal
29-42	SEG1-14	O	LCD segment signal
43-48	NC		Not used

*PDC045A

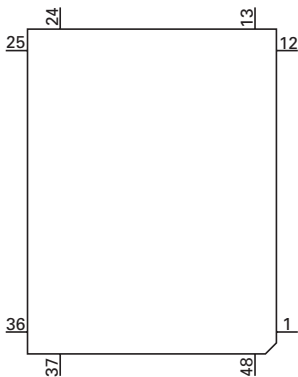

7.2.2 DISPLAY

● CAW1568

SEGMENT

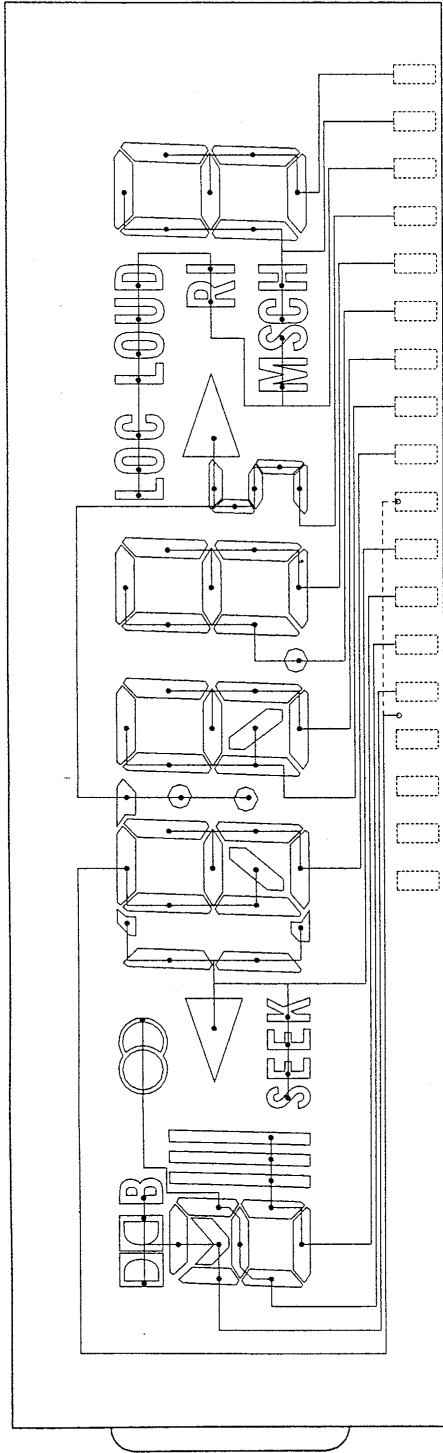

SEG.14
SEG.13
SEG.12
SEG.11
SEG.10
SEG.9
SEG.8
SEG.7
SEG.6
SEG.5
SEG.4
SEG.3
SEG.2
SEG.1

COMMON

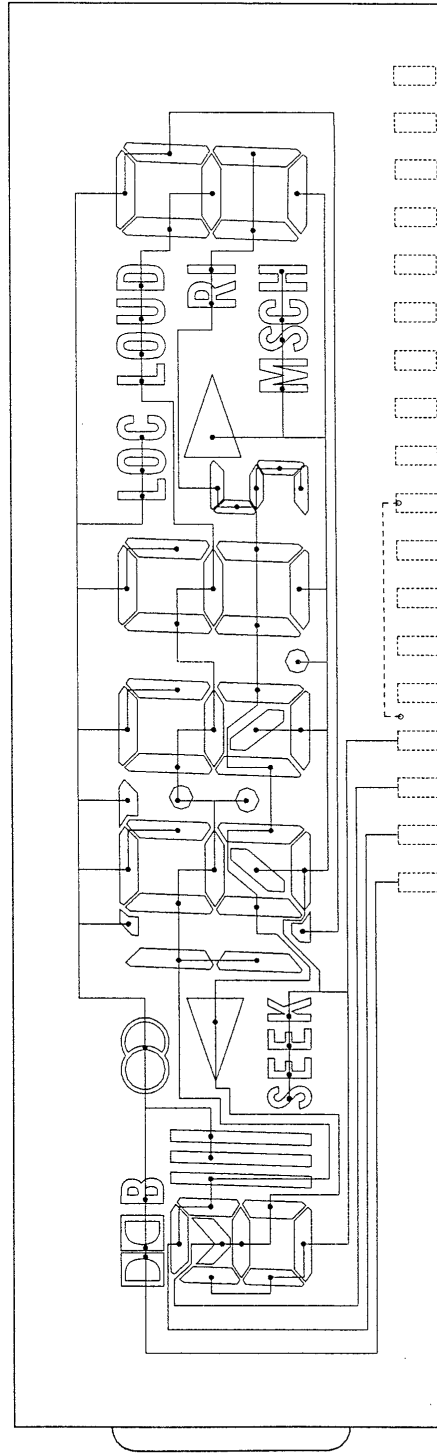

COM.1
COM.2
COM.3
COM.4

8. OPERATIONS AND SPECIFICATIONS

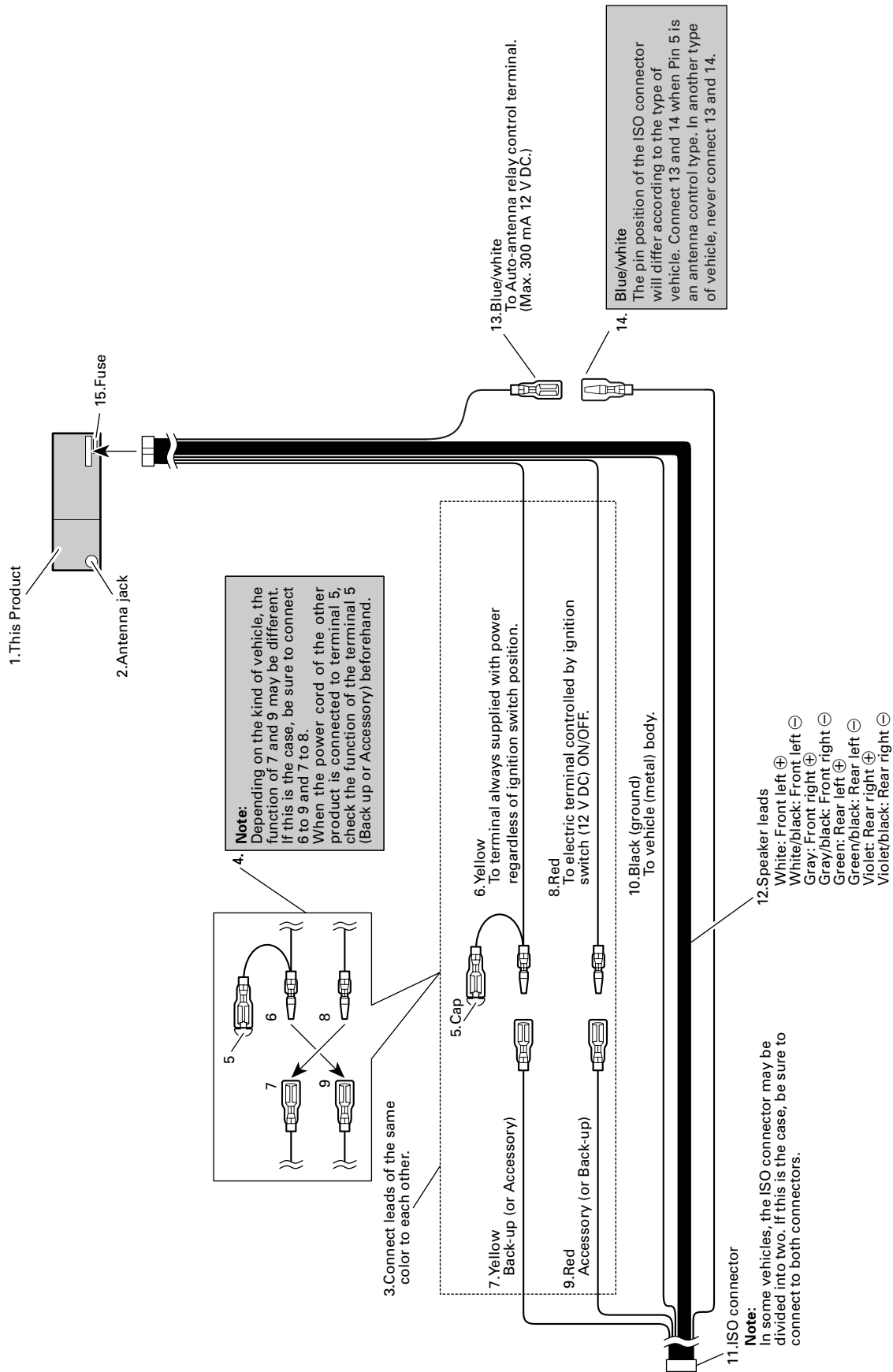

8.1 OPERATIONS

Head Unit

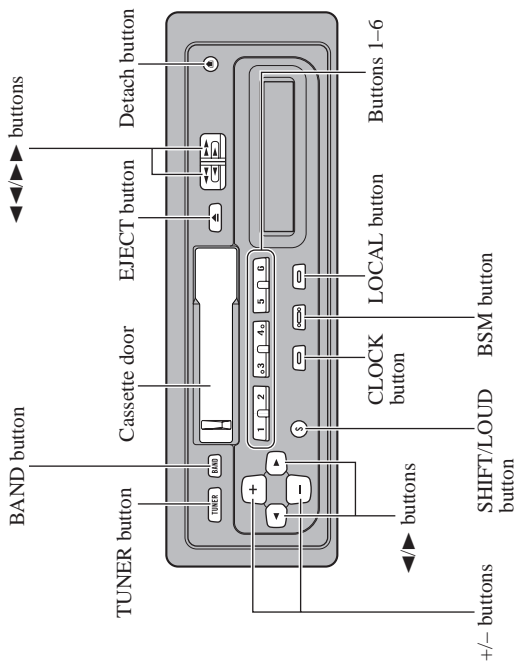

To Listen to Music

The following explains the initial operations required before you can listen to music.

Note:

- Loading a cassette in this product.

1. Press the TUNER button to switch the Tuner ON/OFF.

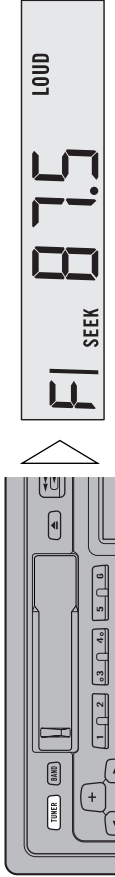

Note:

- You cannot switch to the Tuner when a tape is loaded.
- You cannot switch to the Cassette Player when a tape is not loaded.
- When this product's blue/white lead is connected to the car's Auto-antenna relay control terminal, the car's Auto-antenna extends when this product's power is switched ON. To retract the antenna, switch the power OFF.

2. Raise or lower the volume.

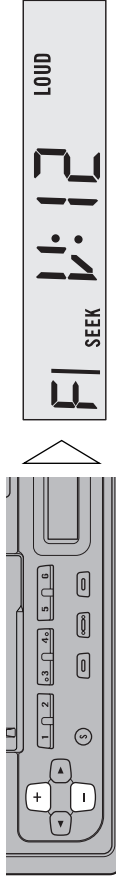

3. Turn the Tuner OFF.

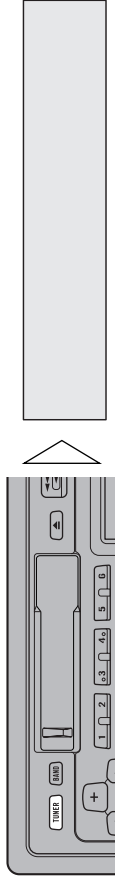

Basic Operation of Tuner

Manual and Seek Tuning

- Press ◀ or ▶ to select a station.

Note:

- You can select the tuning method by pressing the ◀ and ▶ buttons at the same time.
- When the Seek Tuning is selected, "SEEK" lights in the display.
- When the Manual Tuning is selected, "SEEK" goes out from the display.
- Stereo indicator "O" lights when a stereo station is selected.

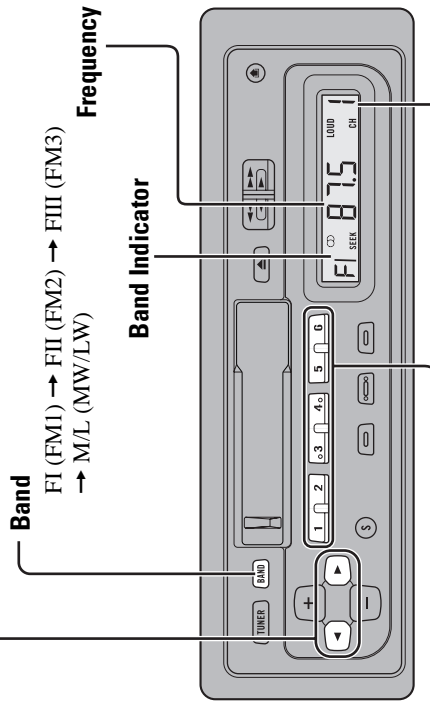

Preset Tuning

- You can memorize broadcast stations in buttons **1 through 6** for easy, one-touch station recall.

Preset station recall	2 seconds or less
Broadcast station preset memory	2 seconds or more

Note:

- Up to 18 FM stations (6 in FI (FM1), FII (FM2) and FIII (FM3)) and 6 MW/LW stations (6 in M/L) can be stored in memory.

Basic Operation of Cassette Player

Fast Forward/Rewind

- To select **Fast Forward**, press the button for the same direction as the **tape play indicator**.
- To select **Rewind**, press the button for the **opposite direction as the tape play indicator**.

Note:

- To release Fast Forward/Rewind, lightly press the ◀◀ or ▶▶ button located on the opposite side of the one you pressed to Fast Forward or Rewind.

Direction Change

- To change the **direction**, press the ◀◀ and ▶▶ buttons at the same time.

Cassette Loading Slot

You can listen to a tape if it is set to this product even when listening to the Tuner.

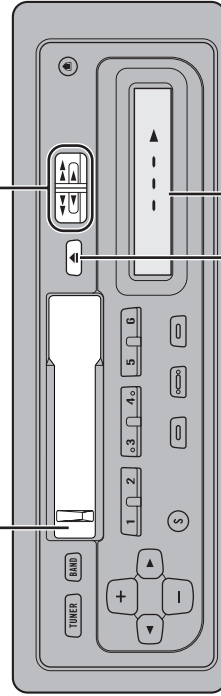

Eject

The power of this product turns OFF when you eject a tape with the EJECT button.

When you listen to the Tuner before a tape is set to this product, the source switches to the radio.

Tape Play Indicator

8.2 SPECIFICATIONS

Specifications

General

Power source	14.4 V DC (10.8 – 15.1 V allowable)
Grounding system	Negative type
Max. current consumption	8.5 A
Dimensions	
(mounting size)	178 (W) × 50 (H) × 150 (D) mm
(front face)	188 (W) × 58 (H) × 20 (D) mm
Weight	1.2 kg

Amplifier

Maximum power output	40 W × 4
Continuous power output	22 W × 4 (DIN45324, +B = 14.4 V)
Load impedance	4 Ω (4 – 8 Ω allowable)
Tone controls	
(Bass)	±12 dB (100 Hz)
(Treble)	±12 dB (10 kHz)
Loudness contour	+10 dB (100 Hz), +7 dB (10 kHz) (volume: –30 dB)

Cassette player

Tape	Compact cassette tape (C-30 – C-90)
Tape speed	4.76 cm/sec. (+0.14 cm/sec., -0.05 cm/sec.)
Fast forward/rewinding time	Approx. 90 sec. for C-60
Wow & flutter	0.13% (WRMS)
Frequency response	40 – 14,000 Hz (±3 dB)
Stereo separation	45 dB
Signal-to-noise ratio	52 dB (IEC-A network)

FM tuner

Frequency range	87.5 – 108 MHz
Usable sensitivity	11 dBf (1.0 μV/75 Ω, mono, S/N: 30 dB)
50 dB quieting sensitivity	16 dBf (1.7 μV/75 Ω, mono)
Signal-to-noise ratio	70 dB (IEC-A network)
Distortion	0.3% (at 65 dBf, 1 kHz, stereo)
Frequency response	30 – 15,000 Hz (±3 dB)
Stereo separation	40 dB (at 65 dBf, 1 kHz)

MW tuner

Frequency range	531 – 1,602 kHz
Usable sensitivity	18 μV (S/N: 20 dB)
Selectivity	50 dB (±9 kHz)

LW tuner

Frequency range	153 – 281 kHz
Usable sensitivity	30 μV (S/N: 20 dB)
Selectivity	50 dB (±9 kHz)

Note:

- Specifications and the design are subject to possible modification without notice due to improvements.